

Product Repair Bulletin

P/N 977122/969305

Compressor Inlet Housing Assembly

NHA: GTCP660 Series APU

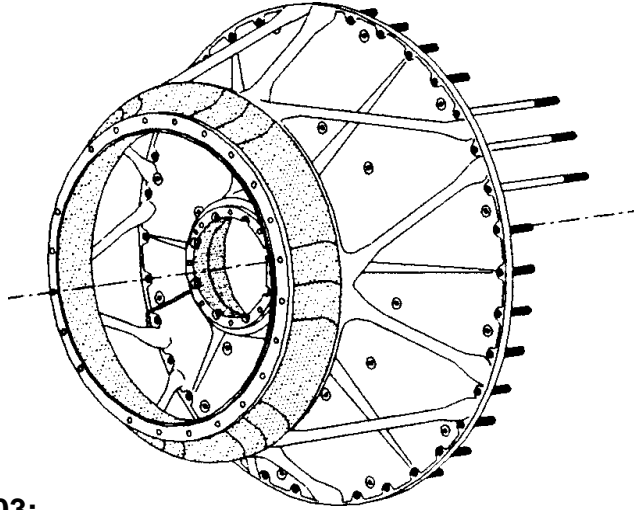

OEM Manual Repairs

Repairs for OEM Manual 49-21-03:

- +Remove scratches/corrosion.
- Dress strut(s).
- Weld repair damaged strut.
- Procure MS51992C644-58R stud.
- Procure MS51997E104P ring.
- Procure MS51992C643-12R stud.
- Procure MS51992C643-14R stud.
- Procure MS51997E103P ring.
- +Procure SF5902C642-9R studs. (8)
- +Procure RLRR1997E102P
- Install studs/rings as required.
- Metallize shroud.
- Metallize diameter B/pilot diameter.
- Metallize surface E.

- Metallize diameter F
- +Metallize surface H.
- Metallize diameter C.
- +Metallize diameter D.
- Machine shroud.
- Machine diameter B/pilot diameter.
- Machine surface E.
- Machine diameter F.
- +Machine surface H.
- Machine diameter C.
- +Machine diameter D.
- +Machine radius T.
- Clean.
- Iridite/paint.

Repairs for Service Bulletin:

Accomplish applicable S/B 49-3191 requirements.

Converts 969305-3 to 977122-1.

Additional FAA Approved Repairs

Repairs for Britt Metal Major Repair 9106111:

Fabricate/Install -40 Aft Mounting Flange.

Fabricate/Install -15 Oil Tube.

Repair for Britt Metal Major Repair 9309271:

Metallize surface A.

Machine surface A.

+ 969305 configuration only.

Product Repair Bulletin

P/N 977122/969305

Compressor Inlet Housing Assembly

