

## Product Repair Bulletin

P/N 968984

### Shroud Support

NHA: GTCP85 Series APU

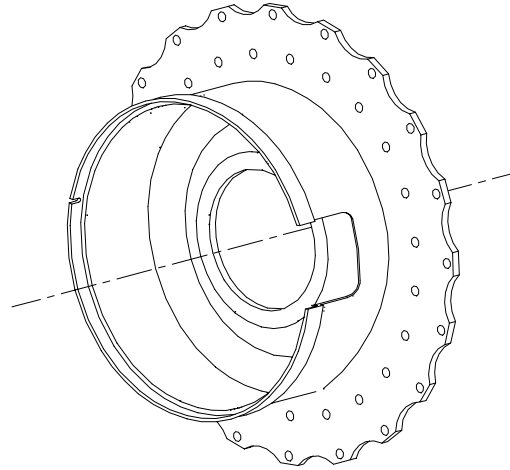

### OEM Manual Repairs

#### Repairs for OEM Manual 49-21-73:

- Dress welds and minor damage.
- Weld diameter R.
- Metallize diameter B/C.
- Metallize diameter A.
- Metallize diameter C.
- Machine surface G.
- Machine surface G for 3601824-1 Spacer.  
*Adds -189 suffix.*
- Machine surface G for 3601824-2 Spacer.  
*Adds -189 suffix.*
- Machine diameter C.
- Machine diameter R.
- Machine diameter B/C.
- Machine diameter A.
- Spot face surface Q bolt holes.

#### Repair for Service Bulletin:

- Machine diameter B/C per S/B 49-3718.  
*Converts 968984-1 to -4.*

### Additional FAA Approved Repairs

#### Repairs for Britt Metal Major Repair 9107246:

- Weld diameter B/C.
- Metal fuse surface G.
- Metal fuse surface K.
- Metal fuse diameter A.
- Weld/Metal fuse diameter C.
- Machine surface K.
- Metal fuse diameter R.

# Product Repair Bulletin

**P/N 968984**  
**Shroud Support**

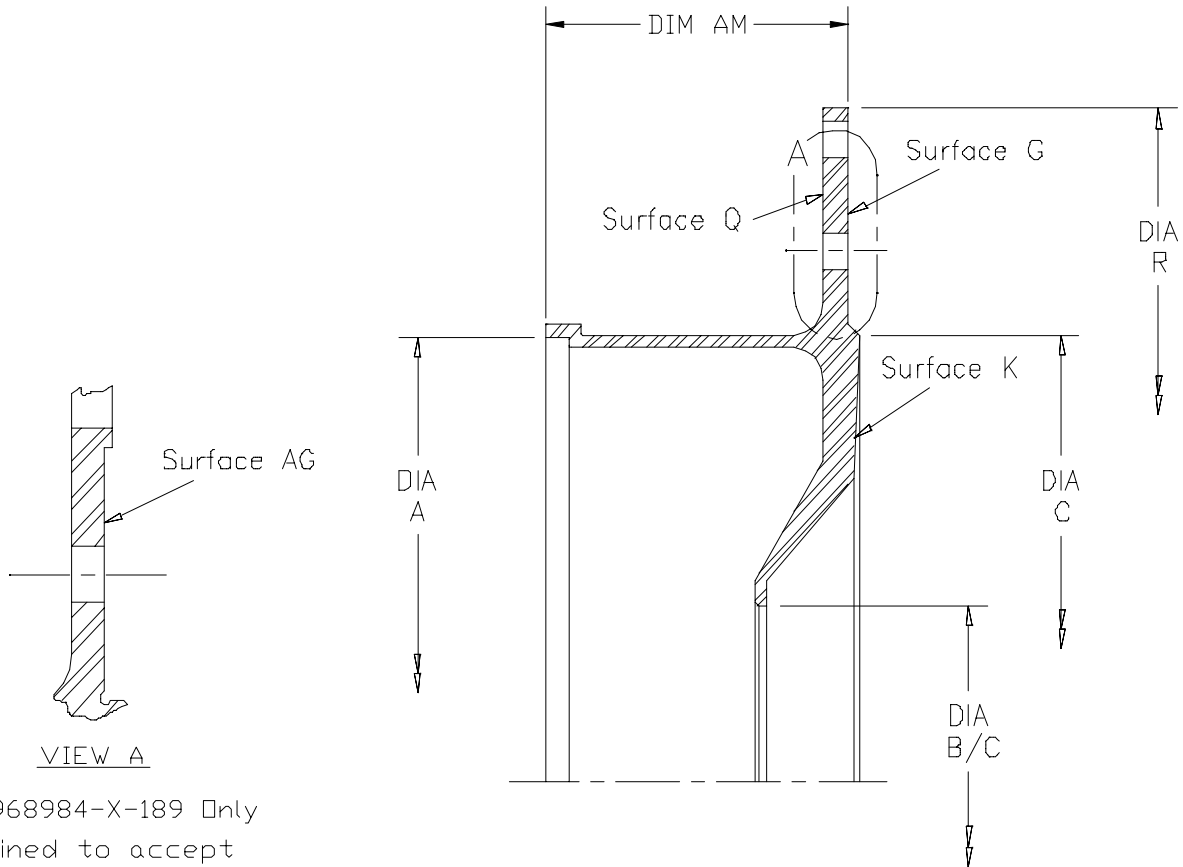

P/N 968984-X-189 Only  
 (Machined to accept  
 360184-1/-2 Spacer)

