

Product Repair Bulletin

P/N 968959/3830350

Turbine Torus Assembly

NHA: GTCP85 Series APU

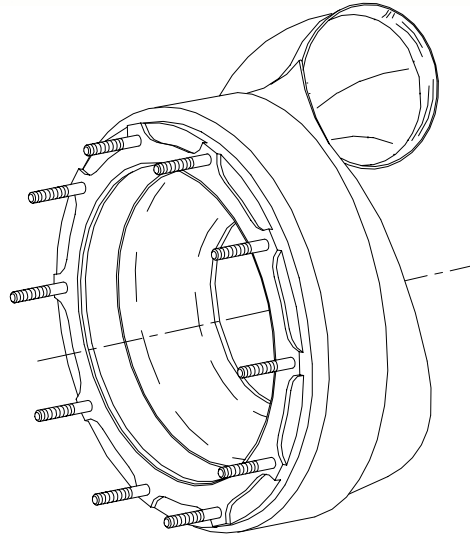

OEM Manual Repairs

Repairs for OEM Manual 49-21-73:

- Weld repair cracks.
- Fabricate/install patch.
- Procure/install 976161-2 stud(s).
- Metallize inlet ring

Repairs for Service Bulletins:

- Install inlet flange per S/B 49-3137.
- Install ring/shield assembly per S/B 49-3137.
Converts 968959-2/-3 to 968959-4/-5/-13.
- Install heat shield mounting flange per S/B 49-5436.
Converts 968959-3/4/5/8/9/11/12 to 968959-23/22/23/22/26/22/22.

Additional FAA Approved Repairs

Repairs for Britt Metal Major Repair 9006201:

- Fabricate/Install -59 Ramp.
- Fabricate/Install -63 Inlet Flange.
- Fabricate/Install -65/-67 Gussets.
- Fabricate/Install -70 Ring.
- Fabricate/Install -75 Ring/Shield Assembly. (heat shield)
- Fabricate/Install -85 Cover.
- Fabricate/Install -88 Flange.(heat shield mount flange)



Product Repair Bulletin

P/N 968959/3830350

Turbine Torus Assembly

