



Product Repair Bulletin

P/N 966618/3600084

First Stage Compressor Stator Assembly

NHA: GTCP660 Series APU

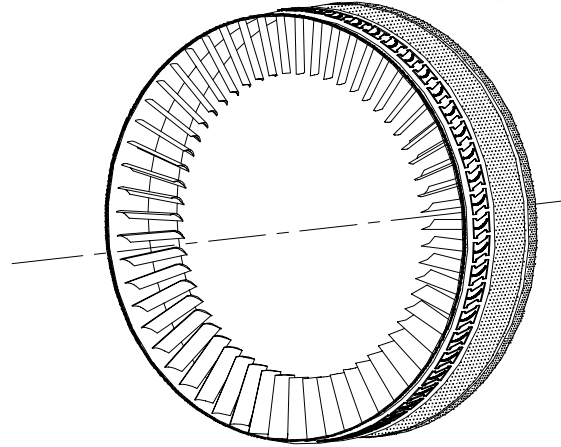

OEM Manual Repairs

Repairs for OEM Manual 49-21-03:

- Repair damaged vanes.
- Machine vanes.
- Metallize/machine diameter R.
- Metallize/machine diameter S.
- Metallize/machine diameter C.
- Metallize/machine surface A.
- Replace dampening adhesive.
- Apply abrasable coating and sealer.
- Apply Sermatel W. (P/N 966618)

Repairs for Service Bulletins:

- Apply Sermatel W per S/B 49-5111.
Converts 3600084-1/2/3/4/5 to 966618-1/2/3/4/5.
- The application of 610NS abrasable coating converts:
From 3600084-1/2 to 3600084-1/2(16724), from 3600084-3 to 3600084-5, from 966618-1/2/3 to 966618-1/2/3 (16724) and from 3600084-4 to 3600084-5 per S/B 49-5926.

Additional FAA Approved Repairs

Repairs for Britt Metal Major Repair 9011191:

- Fabricate/install -1 vane assembly. (57 total)

Repairs for Britt Metal Major Repair 9802021:

- Fabricate/Install -13 shroud.

Product Repair Bulletin

P/N 966618/3600084

First Stage Compressor Stator Assembly

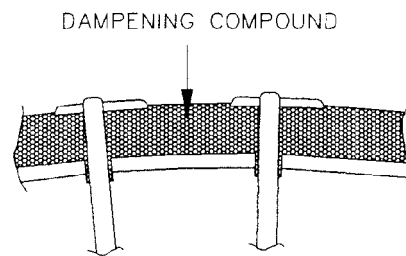
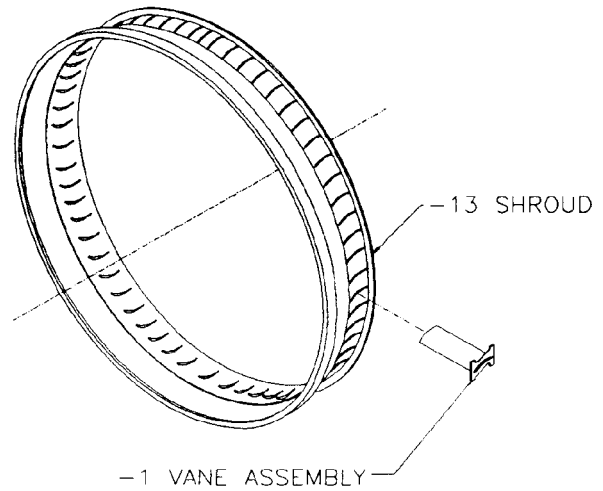
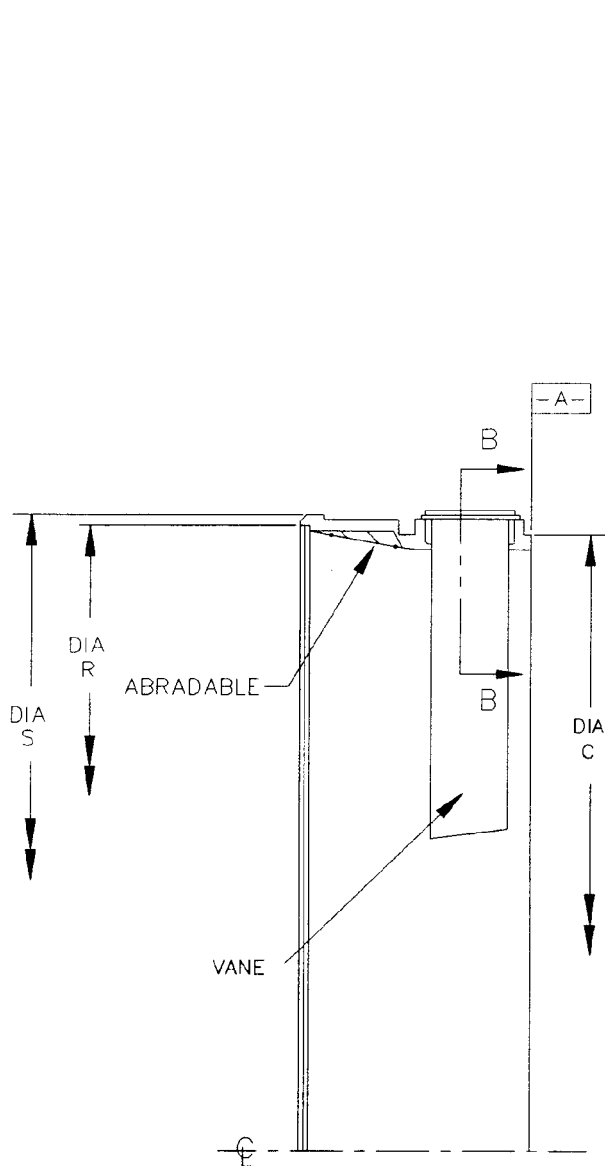

SECTION B-B

