

Product Repair Bulletin

P/N 966617/892892

Fourth Stage Compressor Stator Assembly

NHA: GTCP660 Series APU

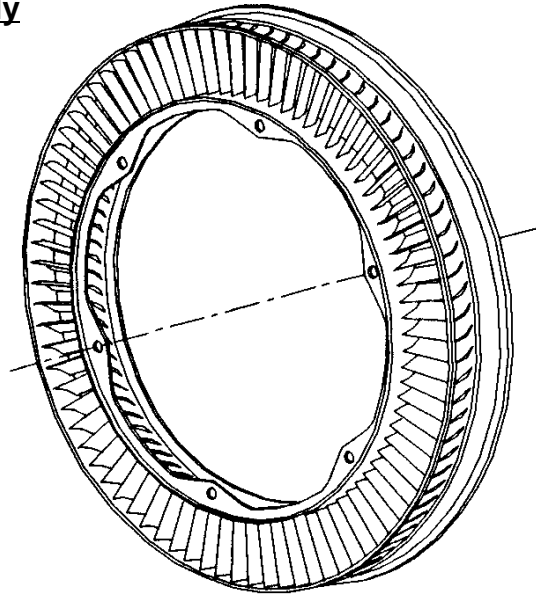

OEM Manual Repairs

Repairs for OEM Manual 49-21-03:

Machine vanes.
Metallize/machine diameter C.
Metallize/machine diameter E.
Metallize/machine diameter N.
Apply abradable coating and sealer.
Apply Sermetel W. (P/N 966617)

Repairs for Service Bulletins:

Install reinforcing ring/machine ID per S/B 49-3807.
Converts 892892-1/2/3 to 892892-4.
Apply Sermetel W per S/B 49-5111.
Converts 892892-1/2/3/4/5/6/7/8 to 966617-1/2/3/4/5/6/7/8.
Apply 610NS abradable coating per S/B 49-5926.
*Converts 892892-1/2/3/4/5/6 to 892892-1/2/3/4/5(16724)/8,
966617-1/2/3/4/5/7 to 966617-1/2/3/4/5(16724)/8 &
892892-7 to 892892-8.*

Additional FAA Approved Major Repairs

Repairs for Britt Metal Major Repair 0007121:

Fabricate/install -1 vanes. (83 total)
Fabricate/install -13 shroud.
Fabricate/install -15 ring.
Fabricate/install -17 flange.



Product Repair Bulletin

P/N 966617/892892

Fourth Stage Compressor Stator Assembly

