



Product Repair Bulletin

P/N 966616/977128

Third Stage Compressor Stator Assembly

NHA: GTCP660 Series APU

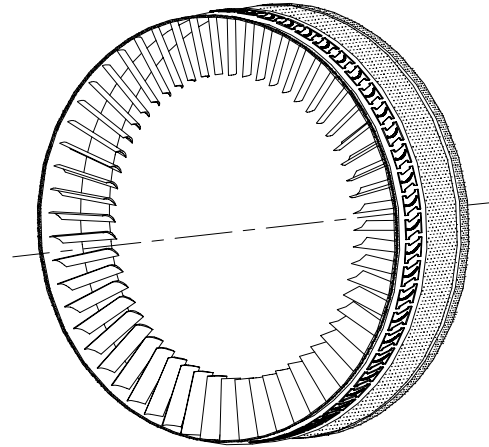

OEM Manual Repairs

Repairs for OEM Manual 49-21-03:

Repair damaged vanes.
Machine vanes.
Metallize/Machine diameter C.
Metallize/Machine diameter E.
Metallize/Machine diameter M.
Metallize/Machine diameter U.
Metallize/Machine surface A.
Procure/install S8152BJ83-0-310 pin.
Procure/install MS16562-189 pin.
Replace dampening adhesive.
Apply abradable coating and sealer.
Apply Sermatel W. (P/N 966616)

Repairs for Service Bulletins:

Apply Sermatel W per S/B 49-5111.
Converts 977128-1/2/3/4/5/6 to 966616-1/2/3/4/5/6.
The application of 610NS abradable coating converts:
From 977128-1/2/3/4 to 977128-1/2/3(16724)/5, from 966616-1/2/3 to 966616-1/2/3(16724), and from 977128-6 to 977128-5, per S/B 49-5926.

Additional FAA Approved Repairs

Repairs for Britt Metal Major Repair 9011191:

Fabricate/install -1 vane assembly. (61 total)

Repairs for Britt Metal Major Repair 9802021:

Fabricate/Install -13 shroud.

Product Repair Bulletin

P/N 966616/977128

Third Stage Compressor Stator Assembly

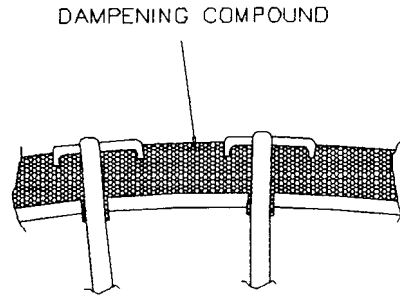
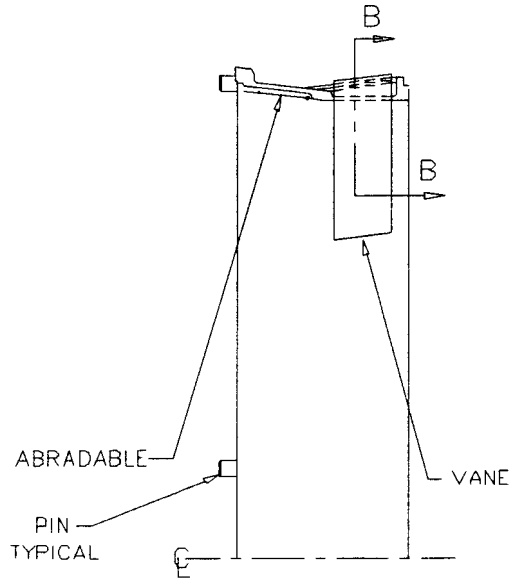

SECTION B-B

