

Product Repair Bulletin

P/N 775470-4/-5

Turbine Housing

NHA: 774469 Air Bearing Air Cycle Machine
Boeing 747-400, 767, L1011

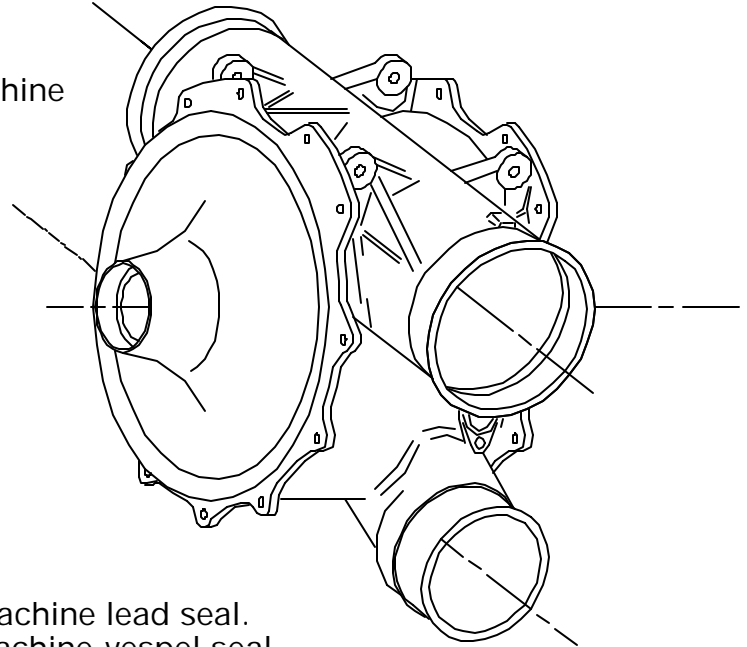

OEM Manual Repairs

Repairs for OEM Manual 21-51-61:

- Repair 3-1 Procure/Install/Finish machine lead seal.
- Repair 7-1 Procure/Install/Finish machine vespel seal.
- Repair 7-2 Rematch seal plate to housing.

Additional FAA Approved Major Repairs

Repairs for Britt Metal Major Repair 0505311:

- | | |
|---------------------------------|-------------------------|
| Metallize contour surface. | Finish machine contour. |
| Metallize Diameters A1, J. | Finish machine. |
| Metallize Surfaces G, H, M. | Finish machine. |
| Mfg./Install -20 ring (Dia A2). | Finish machine. |
| Weld fan shroud edge (Dia E). | Finish machine. |

Repairs for Britt Metal Major Repair 0511151:

- Manufacture/install -30/-31 insert to repair severe damage to Diameter A.
- Manufacture/install -40 plate to repair cracked endplate.
- Relocate/re-match bearing housing to turbine housing alignment pin holes.

Product Repair Bulletin

P/N 775470-4/-5

Turbine Housing

