

Product Repair Bulletin

P/N 775456 / 815956

Nozzle

NHA: 774469 Air Bearing Air Cycle Machine
Boeing 747-400,
767, L1011

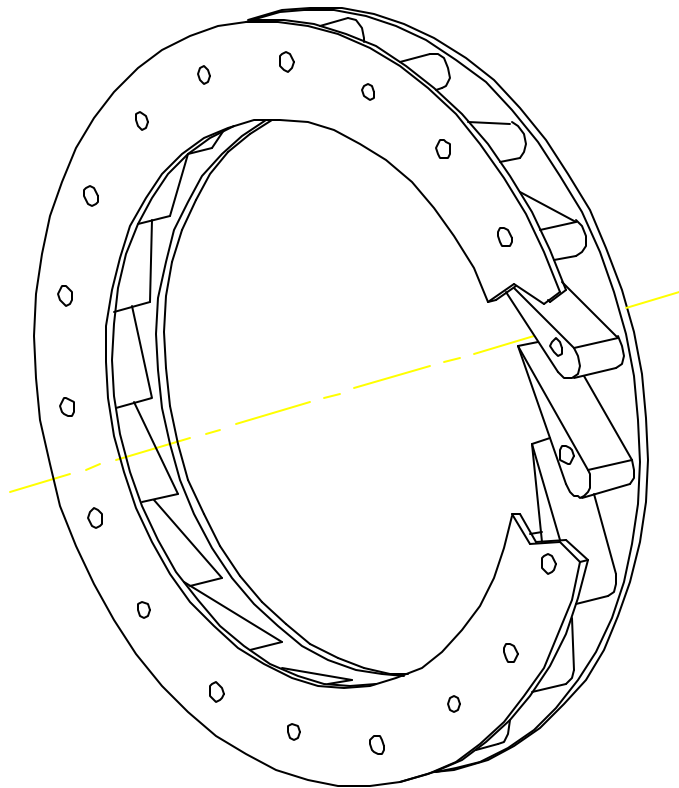

OEM Manual Repairs

None

Additional FAA Approved Major Repairs

Repairs for Britt Metal Major Repair 0506141:

Manufacture/Install -10 Nozzle Insert

Wear Surface Coating Options:

- a. Hard Anodize (default)
- b. Electroless Nickel Plate (-EN suffix)
- c. D-Gun coat wear surfaces (-DG suffix)

Product Repair Bulletin

P/N 775456 / 815956

Nozzle

