



Product Repair Bulletin

P/N 738087

Transition Exhaust Housing

NHA: ST6L Series APU

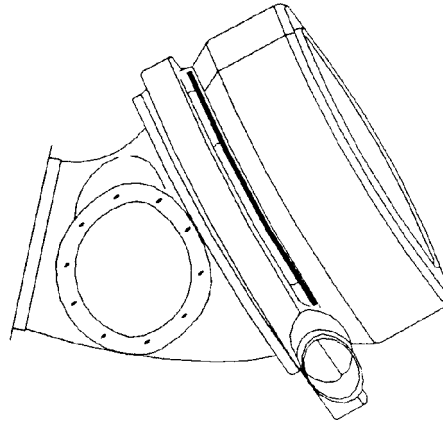

OEM Manual Repairs

Repairs for OEM Manual 49-00-01:

Cold straighten sheet metal.
Weld/dress cracks.

Repair for Service Bulletin:

Re-identify per S/B 49-129.
Converts 738087-2/4/6 to -7.

Additional FAA Approved Repairs

Repairs for Britt Metal Major Repair 9007021:

Fabricate/Install -20 Flange.
Fabricate/Install -130 Segment.
Fabricate/Install -140 Segment.
Fabricate/Install -150 Segment.
Fabricate/Install -112 Cylinder.
Fabricate/Install -42 Shield.
Fabricate/Install -61 Support.
Fabricate/Install -80 Left Distributor.
Fabricate/Install -70 Right Distributor.
Fabricate/Install -100 Inner Connector.
Fabricate/Install -90 Outer Connector.
Fabricate/Install -50 Right Baffle.
Fabricate/Install -30 Left Baffle.
Fabricate/Install -230 Support Extension.
Fabricate -250 Cylinder Extension.
Procure MS20615-4M5 Rivet. (60)
Set-up to install rivets as required.
Install MS20615-4M5 Rivet. (60)

Product Repair Bulletin

P/N 738087

Transition Exhaust Housing

