



## Product Repair Bulletin

P/N 727467

Turbine Nozzle

NHA: 719238 Air Cycle Machine

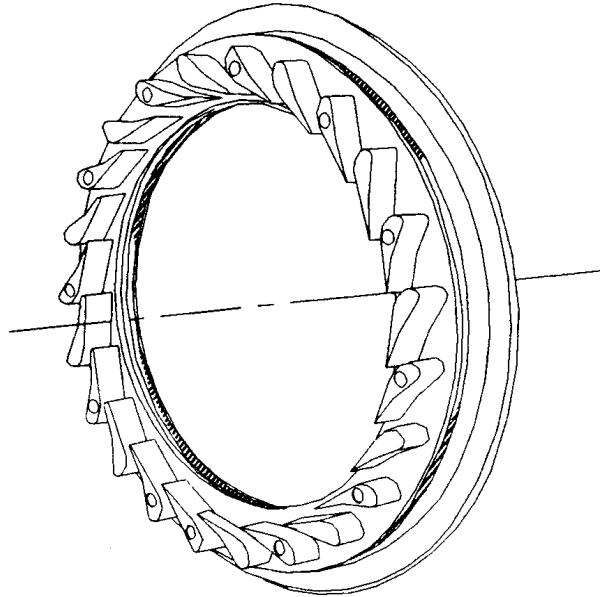

### OEM Manual Repairs

#### Repairs for OEM Manual 21-51-03:

Touch up per AMS2473.

### Additional FAA Approved Repairs

#### Repairs for Britt Metal Major Repair 9002151:

Weld repair flange cracks.

Patch repair flange.

Metallize Diameter F.

Metallize Diameter N.

Metallize Surface Z.

Fabricate/install -24F nozzle blank.

Hard anodize per MIL-A-8625, Type III. (-2 configuration)

D-Gun coat with tungsten carbide. (-3 configuration)

# Product Repair Bulletin

P/N 727467

Turbine Nozzle

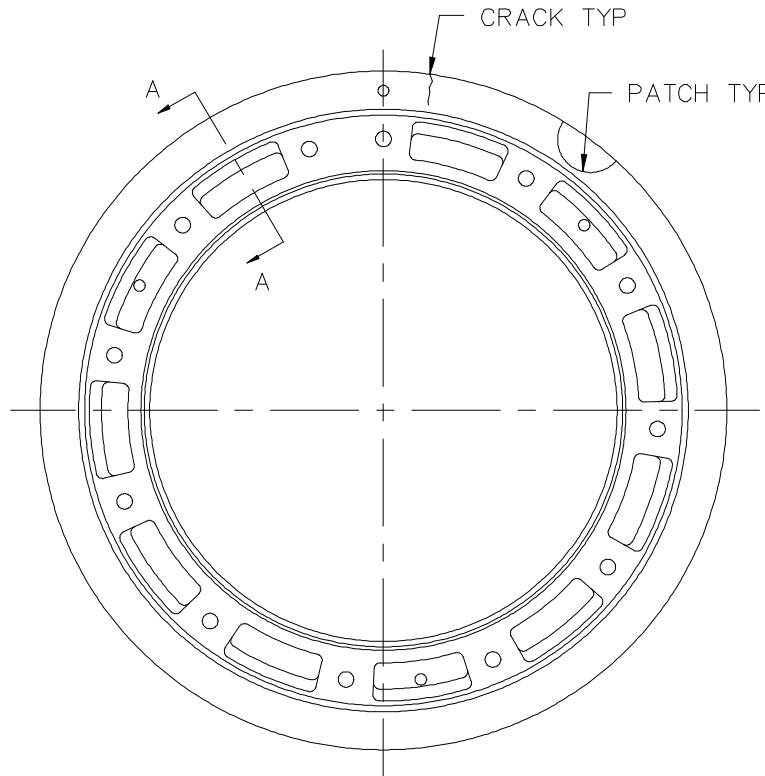

TURBINE NOZZLE

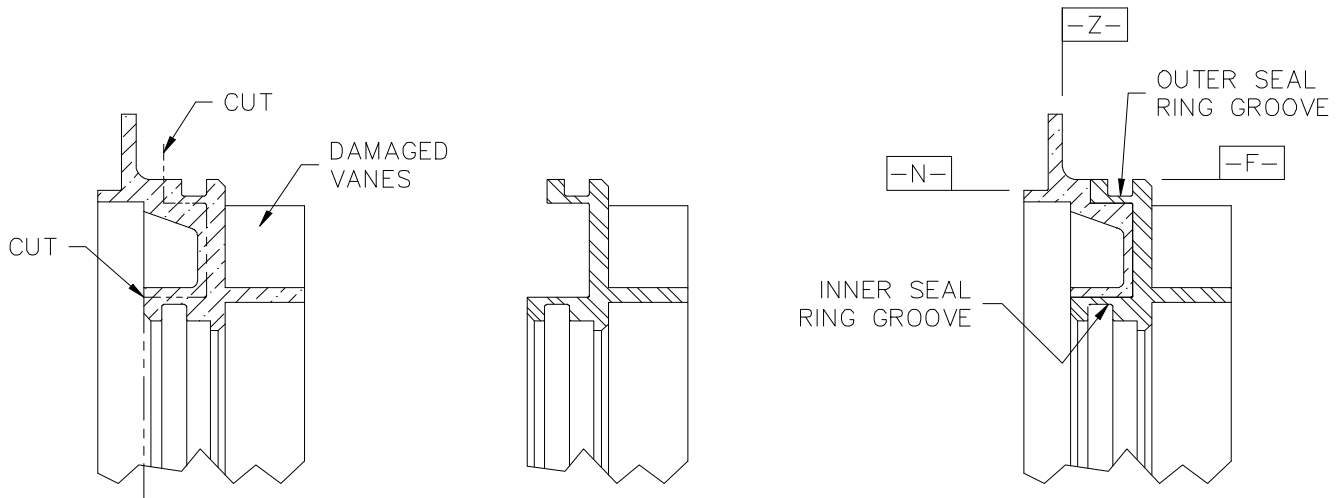

CUT TO REMOVE  
DAMAGED VANES

-24F NOZZLE BLANK

SECTION A-A