



## Product Repair Bulletin

P/N 727450

### Compressor Housing

NHA: 719238 Series Air Cycle Machine

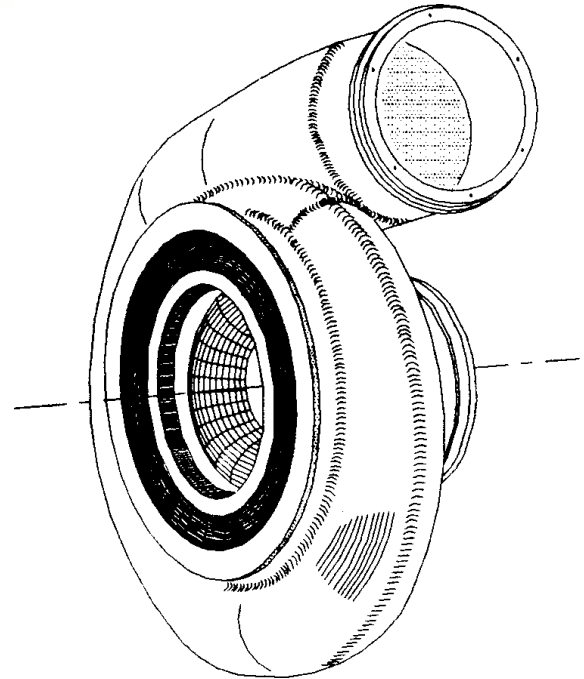

### OEM Manual Repairs

#### Repairs for OEM Manual 21-51-03:

- Procure 727450-800 shroud.
- Fabricate/install patch.
- Machine contour-shroud area.
- Weld/dress cracks.
- Pressure test.
- Anodize housing per AMS 2471.
- Clean/iridite.

### Additional FAA Approved Repairs

#### Repairs for Britt Metal Major Repair 9108062:

- Fabricate -700 insert.
- Install insert/shroud.
- Metallize contour-shroud area.
- Metallize surface L.
- Metallize diameter A/seal ring groove.
- Machine surface L.
- Machine diameter A/seal ring groove.



# Product Repair Bulletin

P/N 727450

Compressor Housing

