

Product Repair Bulletin

P/N 698198/379518

Interstage Housing Assembly

NHA: GTCP85 Series APU

OEM Manual Repairs

Repairs for OEM Manual 49-21-73:

Dress minor damage of surface F.
Metallize surface F.
Primer buildup surface F.
Metallize diameter A.
Metallize diameter B.
Metallize surface E.
Metallize diameter C/o-ring groove.
Machine surface F.
Machine diameter A.
Machine diameter B.
Machine surface E.
Machine diameter C/o-ring groove.
Fabricate/install -20 contour plug.
Clean/iridite.
Apply epoxy paint.
Set-up to install mount pad inserts as required.
Procure/install MS21209C1-15 insert. (28)
*Cone lip replacement is accomplished by
- = Fabricate/install -19 Plug = - per Britt Metal Major Repair 9107243.*

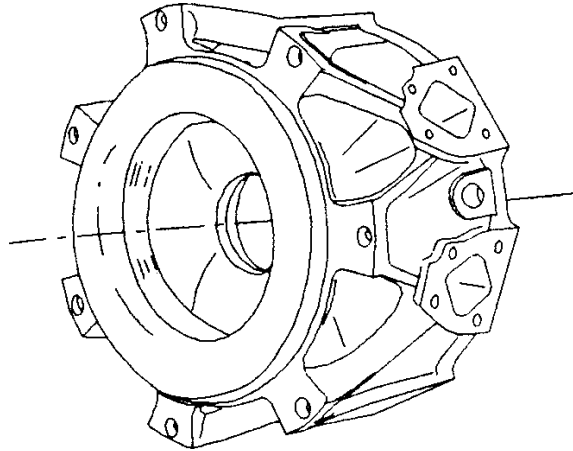

Repair for Service Bulletin:

Machine contour
Converts 379518 to 698198 per S/B 49-5629

Additional FAA Approved Repairs

Repairs for Britt Metal Major Repair 9107243:

Fabricate/install -21 oversize plug.
Weld/dress non-structural areas.
Fabricate/install -19 plug.
Metallize diameter L.
Machine diameter L.
Restore corroded crossover tube mating surfaces.

Product Repair Bulletin

P/N 698198/379518
Interstage Housing Assembly

