

Product Repair Bulletin

P/N 698197/379713

Inlet Housing Assembly

NHA: GTCP85 Series APU

OEM Manual Repairs

Repairs for OEM

Manual 49-21-73:

Set-up to install hardware as required.
Procure/install MS51989E105-12 stud. (11)
Procure/install MS51991E-106L insert.
Procure/install MS21209C1-15 insert. (22)
Dress minor damage of surface F.
Metallize surface F contour.
Primer buildup of surface F contour.
Metallize diameter A.
Metallize diameter B/o-ring groove.
Metallize surface C.
Metallize diameter Q.
Machine diameter A.
Machine diameter B/O-ring groove.
Machine surface C.
Machine diameter Q.
Fabricate/install -20 contour plug.
Fabricate/install diameter A plug.
Fabricate/install diameter CA plug.
Machine diameter CA.
Clean/iridite.
Apply epoxy paint.

Repair for Service Bulletin:

Machine surface F contour per S/B 49-5630.
Converts 379713 to 698197.
Procure/install screw set per S/B 49-5996.
Converts 698197-1 to -2.

Additional FAA Approved Repairs

Repairs for Britt Metal Major Repair 9108011:

Fabricate/install oversize -21 plug.
Weld/dress non-structural areas.
Metallize diameter CA.
Weld build-up diameter CA.

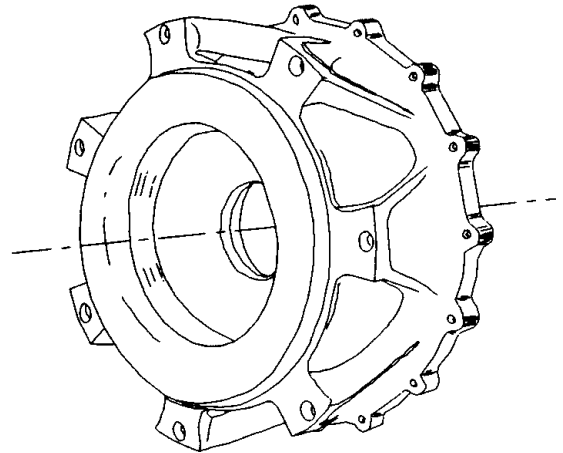

Product Repair Bulletin

P/N 698197/379713

Inlet Assembly

