



Product Repair Bulletin

P/N 696658/966584

Support Assembly

NHA: GTCP85 Series APU

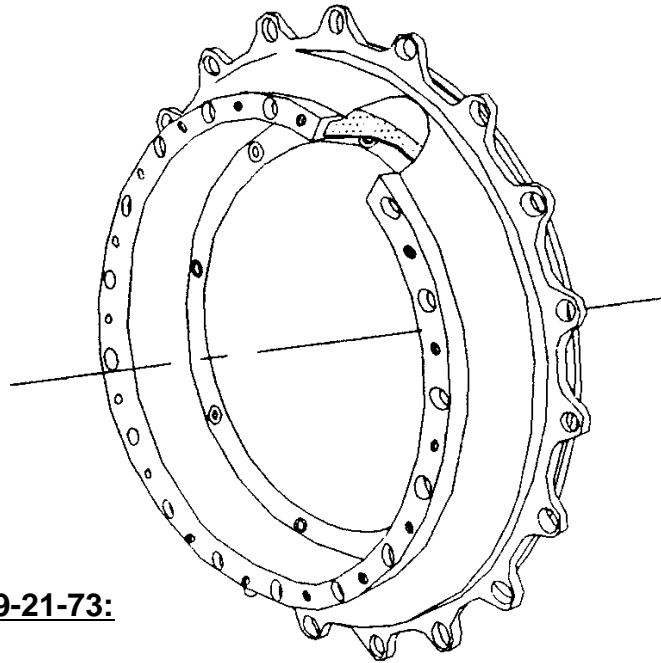

OEM Manual Repairs

Repairs for OEM Manual 49-21-73:

Machine (-15) ring.

Weld/dress cracks.

Weld/dress bolt hole/scallop flange. (-13 Flange)

Repair for Service Bulletin:

Drill holes/machine OD per S/B 49-3688.

Converts 696658-1 to 966584-1.

Drill holes/machine OD per S/B 49-5807

Converts 696658-1 to 966584-5.

Additional FAA Approved Repairs

Repairs for Britt Metal Major Repair 9002121:

Fabricate/install -15 Ring.

Fabricate/install -21 Cylinder.

Fabricate/install -17 Ring.

Fabricate/install -19 Cone.

Metal fuse dimensions of -13 Flange.

Metal fuse dimensions of -17 Ring.

Metal fuse dimensions of -15 Ring.

Machine -13 Flange.

Machine -17 Ring.

Product Repair Bulletin

P/N 696658/966584

Support Assembly

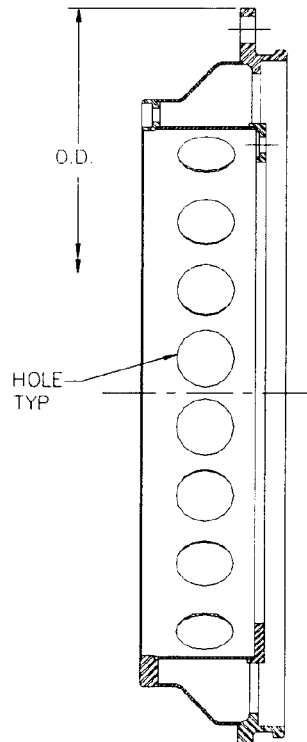
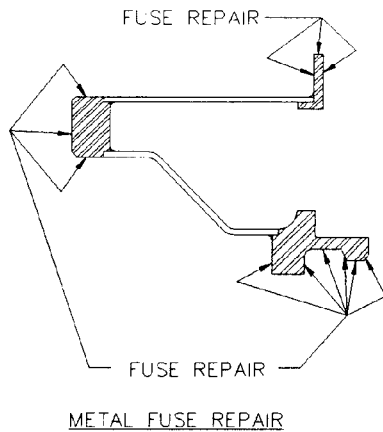
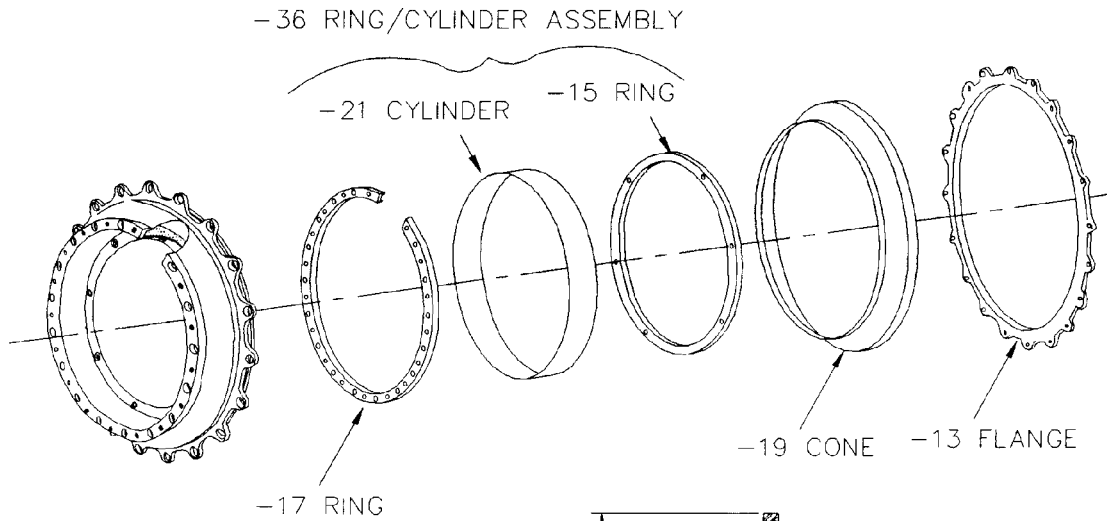

S/B 49-3688
DRILL HOLES & MACHINE O.D.