

## Product Repair Bulletin

P/N 977230

### Fan Housing Assembly

NHA: GTCP85 Series APU

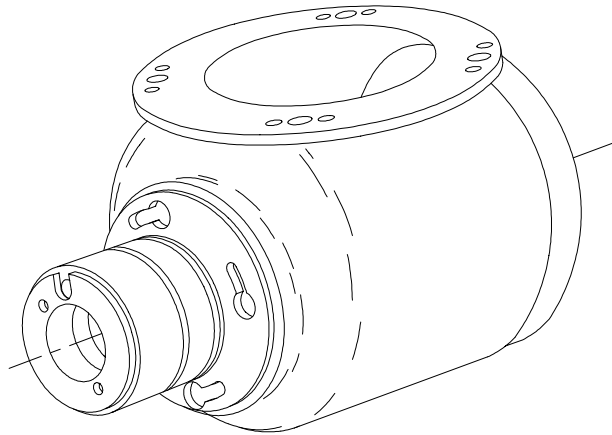

### OEM Manual Repairs

#### **Repairs for OEM Manual 49-50-37:**

- Replace damaged hardware as required.
- Procure/Install 977230-15 Set Screw.
- Procure/Install 977230-17 Ring.
- Fabricate/Install 695244-6001 Sleeve.
- Weld/dress duct mounting flange.
- Weld/dress surface A mounting flange.
- Metallize surface A.
- Metallize diameter F.
- Metallize diameter L.
- Metallize diameter R.
- Metallize diameter AK.
- Metallize diameter AH.
- Machine surface A.
- Machine diameter F.
- Machine diameter L.
- Machine diameter R.
- Machine diameter AK.
- Machine diameter AH.
- Pressure check.
- Clean/chrome pickle/iridite.
- Apply epoxy paint.

#### **Repairs for Service Bulletins:**

- Machine diameter L and R per S/B 49-5238.  
*Converts 977230-3 to -4.*
- Machine housing per S/B 49-5433.  
*Converts 977230-4 to -5.*



# Product Repair Bulletin

P/N 977230

Fan Housing Assembly

