

Product Repair Bulletin

P/N 693531/977831

Matched Housing Assembly Set

NHA: GTCP85 Series APU

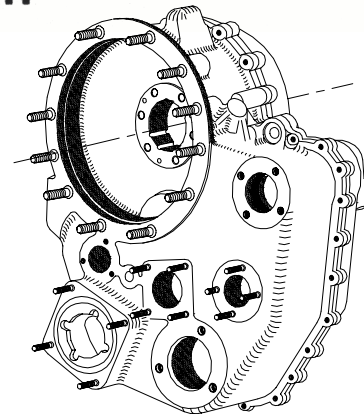

OEM Manual Repairs

Repairs for OEM Manual 49-21-73:

Repair minor surface defects/apply epoxy paint.
Set-up to install hardware as required.
Procure/install SFA121-12SA18A pad 1 stud.
+Procure/install S15F121-12SA26A pad 1 stud.
Procure/install M45932-1-9L pad 2 insert.
Procure/install NAS1394C4 pad 3 insert.
Procure/install MS51989E105-14 pad 4 stud.
Procure/install SB101-9SA8A pad 4 stud.
Procure/install SFA101-9SA12A pad 5 stud.
Procure/install SB101-9SA8A pad 5 stud.
Procure/install SR142 pad 6 insert.
Procure/install NAS1395C4 pad 7 insert.
Procure/install M45932-1-9L pad 8 insert.
Procure/install MS51989E105-12 pad 9 stud.
Procure/install M45932-1-9L pad 10 insert.
Procure/install M45932-1-9L pad 11 insert.
Procure/install M45932-1-9L pad 12 insert.

Procure/install NAS1395C6L mount pad insert.
Procure/install M45932-1-9L flange insert.
++Procure/install NAS1396C8 oil fitting insert.
Metallize diameter FE.
Metallize diameter A.
Machine diameter FE.
Machine diameter A.
Weld/dress cracks in ribs.
Modify Bushing for oversized housing bore.
Repair cracked lug for hole number 7.
Procure/install nozzle/stud assembly hardware.
Fabricate/install sleeve to restore oil jet bore.
Repair idler spur gearshaft boss.
Fabricate/install boss for output oil passage.
Fabricate/install plug for high speed pinion bore.
Clean/apply protective coating.

Repairs for Service Bulletins:

Machine anti-rotation groove per S/B 49-3232 is accomplished by installing diameter B bushings/anti-rotation groove.
Machine to accept nozzle/stud assembly per S/B 49-3251.
Convert existing 693531-X by adding -X-J153 suffix or 977831-5 if S/B 49-3232 has been accomplished.

Additional FAA Approved Repairs

Repairs for Britt Metal Major Repair 9105061:

Fabricate/install/machine Steel bushings.
Fabricate/install/machine alignment pin bushings
Fabricate/install/machine diameter H sleeves.
Fabricate/install/machine diameter K sleeves.
Fabricate/install/machine diameter Q sleeves.
Fabricate/install/machine diameter AX sleeves.
Fabricate/install/machine diameter S sleeves.
Weld restore/machine diameter N sleeves.

Weld restore/machine diameter E.
Weld restore/machine diameter WW.
Weld restore/machine diameter engine mount pad.
Metallize/machine diameter E.
Metallize/machine diameter WW.
Metallize/machine engine mount pad.
Metallize/machine surface BB.
Metallize/machine diameter F.

Repairs for Britt Metal Major Repair 9211301:

Weld/dress cracks/damage beyond OEM manual specification.

+ P/N 693531-200/-200-J153 only.

++ P/N 693531/-150/-4/-J153/-150-J153/-200-J153, 977831-1/-5 only.

Product Repair Bulletin

P/N 693531/977831
Matched Housing Assembly Set

