



Product Repair Bulletin

P/N 681668-4/-6/-8/-10, 2205717-1

Scroll Housing

NHA: Air Cycle Machine 204905

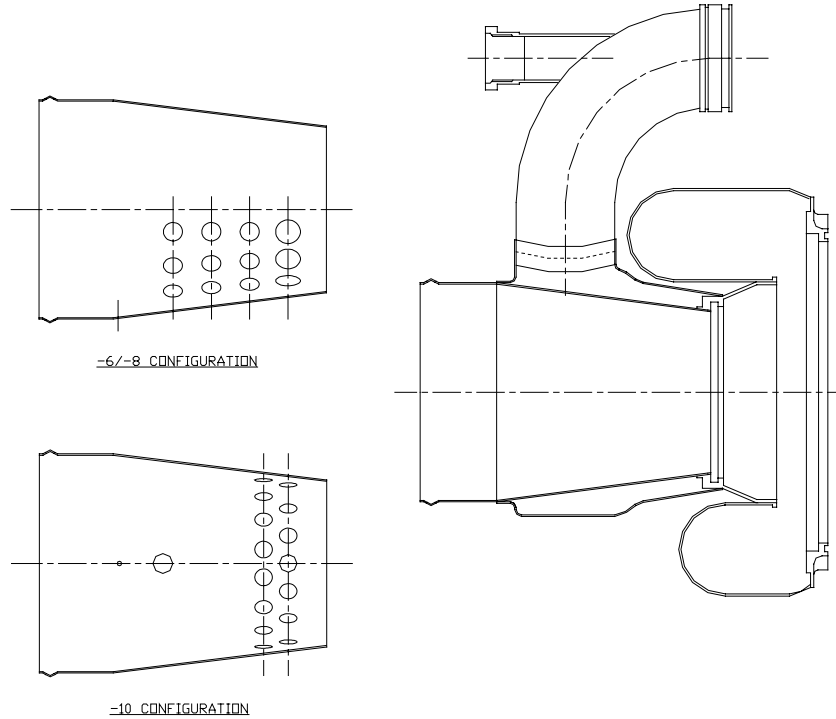

OEM Manual Repairs

Repairs for OEM Manual 21-53-26:

Replace Pins/Inserts.
Replace drain boss/pressure sense port.
FPI.

Weld Cracks.
Repair anti-icing duct.
Pressure Test.

Additional FAA Approved Major Repairs

Repairs for Britt Metal Major Repair 0607131:

Convert housing to -10MOD.
Metal spray Diameter B.
Weld Repair Diameter A/Surface C.

Finish Machine.
Finish Machine.



Product Repair Bulletin

P/N 681668-4/-6/-8/-10, 2205717-1

Scroll Housing

