



Product Repair Bulletin

P/N 3844009

Second Stage Stator Support

NHA: GTCP331 Series APU

OEM Manual Repairs

Repairs for OEM Manual 49-23-49:

- Metallize surface D.
- Metallize surface P.
- Metallize surface N.
- Metallize diameter B.
- Metallize diameter K.
- Metallize diameter J.
- Machine surface D.
- Machine surface P.
- Machine surface N.
- Machine diameter B.
- Machine diameter K.
- Machine diameter J.

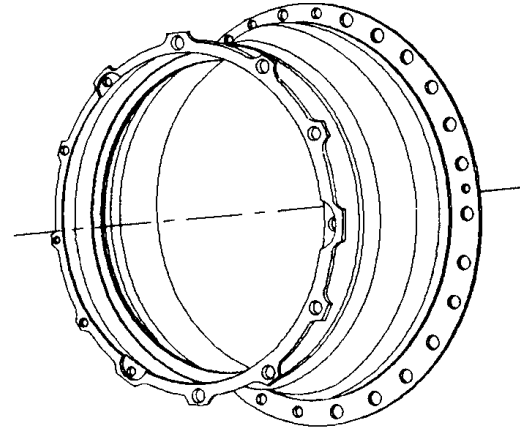

Additional FAA Approved Repairs

Repairs for Britt Metal Major Repair 9101211:

- Weld/dress cracks in forward flange.
- Metal fuse surface Y.
- Metal fuse surface Z.
- Metal fuse surface G/cut-outs.
- Metal fuse surface N.
- Metal fuse surface P.
- Metal fuse diameter K.
- Metal fuse diameter X.
- Metal fuse diameter J.
- Machine surface Y.
- Machine surface Z.
- Machine surface G/cut-outs.
- Machine diameter X.
- Machine/ lap surface A.
- Cold straighten surface G

Repairs for Britt Metal Major Repair 9204071:

- Fabricate/install -901 flange.

Repairs for Britt Metal Major Repair 9301041:

- Fabricate/install -905 duct.

Product Repair Bulletin

P/N 3844009

Second Stage Stator Support

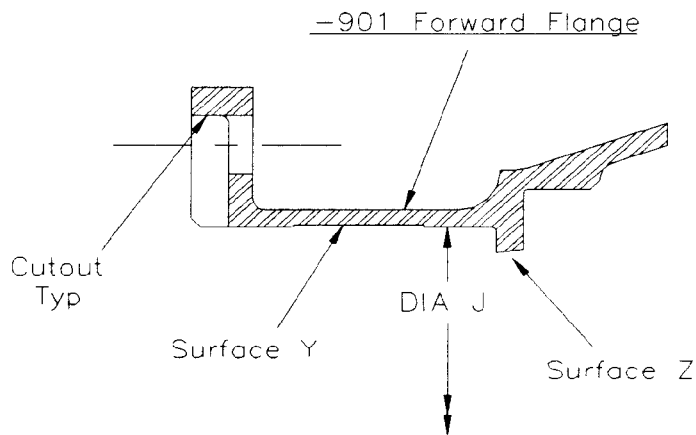
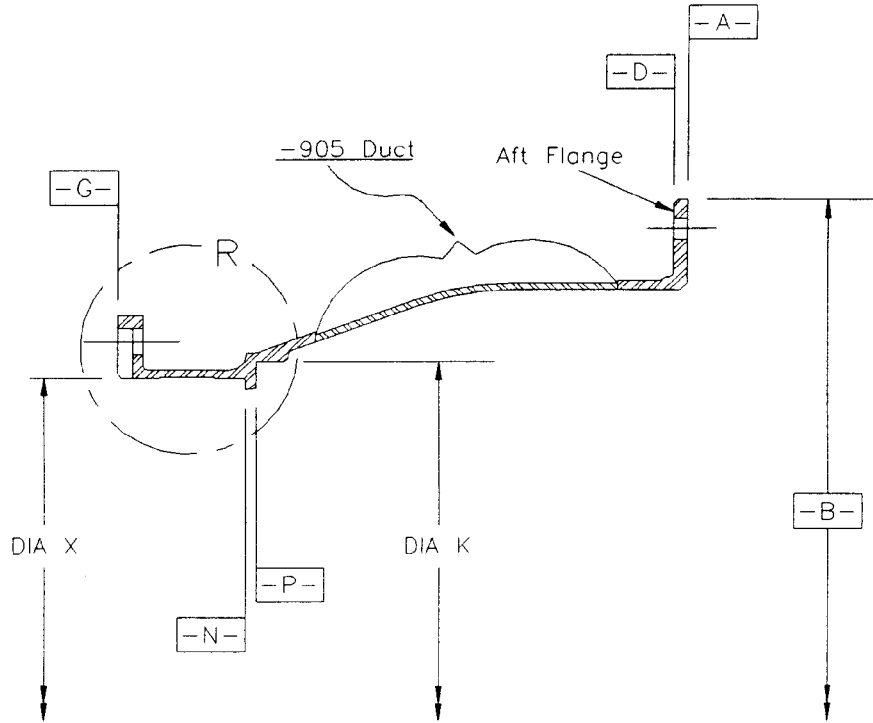

View R

