



Product Repair Bulletin

P/N 3844008

First Stage Turbine Shroud

NHA: GTCP331 Series APU

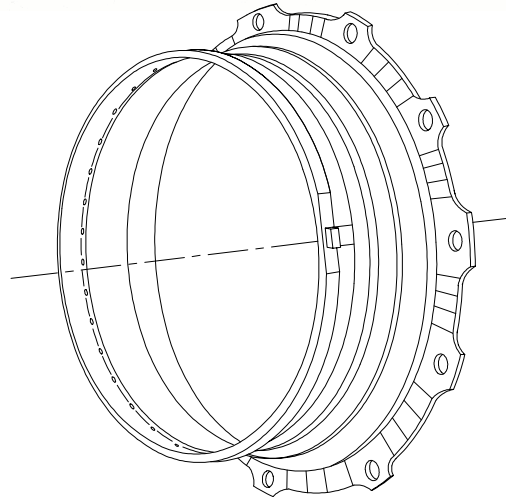

OEM Manual Repairs

Repairs for OEM Manual 49-29-49:

- Metallize diameter B.
- Metallize diameter F.
- Metallize diameter G.
- Metallize diameter H.
- Machine diameter B.
- Machine diameter F.
- Machine diameter G.
- Machine diameter H.
- Apply thermal barrier coating.

Additional FAA Approved Repairs

Repairs for Britt Metal Major Repair 9102011:

- Weld aft flange cracks.
- Metallize surface J.
- Metallize surface L.
- Metallize diameter M.
- Metallize surface A.
- Machine surface J.
- Machine surface L.
- Machine diameter M.
- Machine surface A.
- Restore tangs, 3 total. (-1 configuration)
- Replace -70 pins, 3 total. (-2 configuration)
- Fabricate/Install -60/-80 ring.

P/N 3844008
Issue 01/99
Section 1



Product Repair Bulletin

P/N 3844008

First Stage Turbine Shroud

