

Product Repair Bulletin

P/N 3844007

First Stage Stator Support

NHA: GTCP331 Series APU

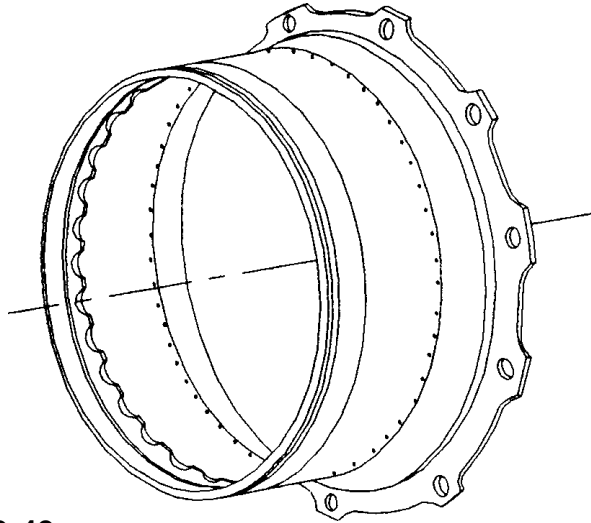

OEM Manual Repairs

Repairs for OEM Manual 49-23-49:

- Weld/dress cracks.
- Metallize diameter B.
- Metallize surface of forward flange - dimension F.
- Metallize surface A.
- Machine diameter B.
- Machine surface of forward flange - dimension F.
- Machine surface A.

Press for Photo

Additional FAA Approved Repairs

Repairs for Britt Metal Major Repair 9310251:

- Metallize diameter H.
- Metallize diameter G.
- Metallize diameter N.
- Metallize surface M.
- Metallize surface X.
- Metallize seal ring groove.
- Machine diameter H.
- Machine diameter G.
- Machine diameter N.
- Machine surface M.
- Machine surface X.
- Machine seal ring groove.
- Fabricate/install -10 forward flange.
- Fabricate/install -50 aft flange

Product Repair Bulletin

P/N 3844007

First Stage Stator Support

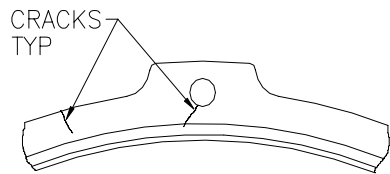
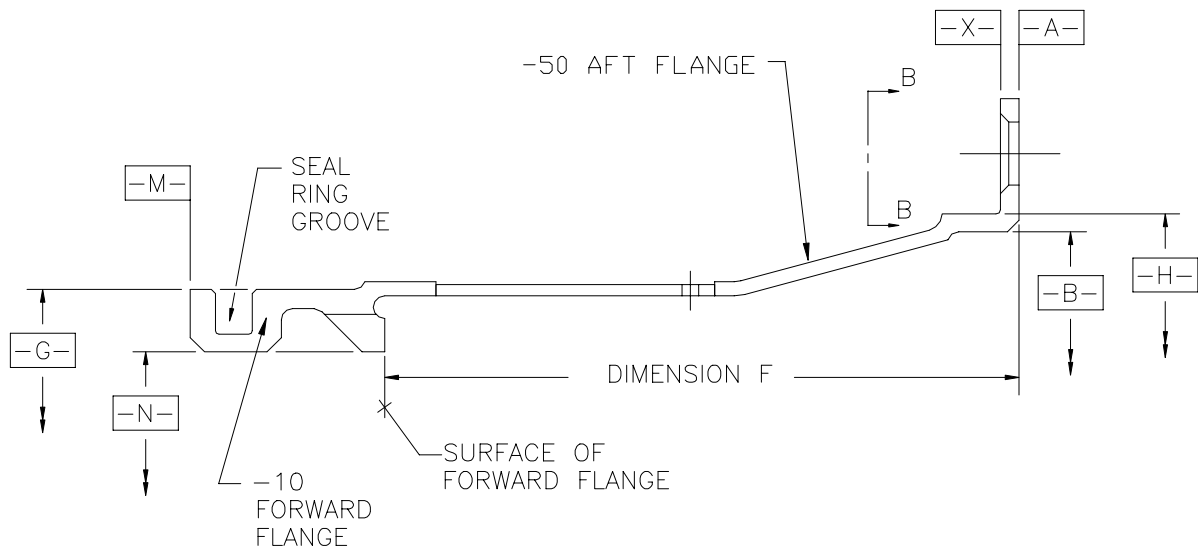

VIEW B-B

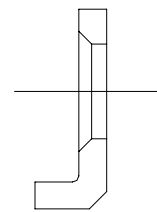

-50 AFT FLANGE

