

Product Repair Bulletin

P/N 3844001

Combustion Transition Liner Assembly

NHA:GTCP331SerieAPU

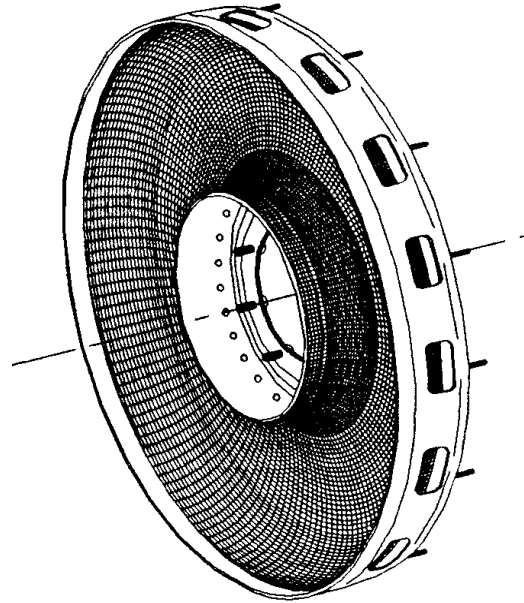

OEM Manual Repairs

Repairs for OEM Manual 49-23-49:

- Procure NAS1216-3E9 bolt.(8)
- Fabricate/install -10 stud.(17)
- Fabricate/install -20 flange/sleeve assembly.
- Set-up to install stud(s) as required.
- Set-up to install bolt(s) as required.
- Install bolt.(8)
- Metal spray diameter B.
- Metal spray diameter J.
- Machine diameter B.
- Machine diameter J.

Additional FAA Approved Repairs

Repairs for Britt Metal Major Repair 9605221:

- Weld/dress cracks in outer ring.
- Strip thermal coating.
- Apply thermal coating to liner.
- Converts 3844001-1 to 3844001-3*
- Fabricate/install -931 liner.

Product Repair Bulletin

P/N 3844001

Combustion Transition Liner Assembly

