

## Product Repair Bulletin

P/N 3826825

### VGD Vane Assembly

NHA: GTCP36 Series APU

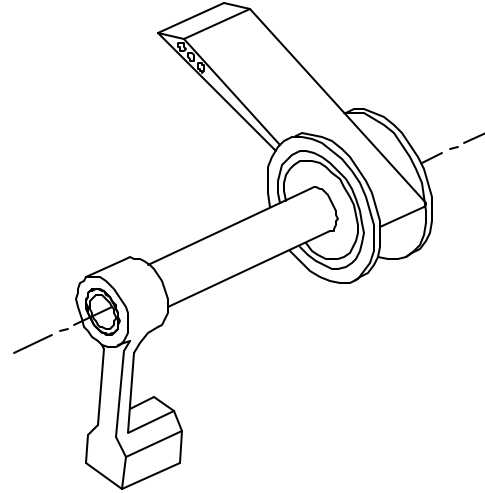

### Additional FAA Approved Major Repairs

#### Repairs for Britt Metal Major Repair 0207231:

Weld Repair Vane Tip.

Fabricate/Install -100 Vane Insert.

Fuse Repair Diameter A1.

Fuse Repair Diameter B.

Fuse Repair Diameter C1.

Fuse Repair Diameter L.

Fuse Repair Surfaces A.

Fuse Repair Surfaces B.

Fuse Repair Surfaces D.

Fuse Repair Surfaces E.

Fuse Repair Surfaces J.

Machine/Grind Diameter A1.

Machine/Grind Diameter B.

Machine/Grind Diameter C1.

Machine/Grind Diameter L.

Machine/Grind Surfaces A.

Machine/Grind Surfaces B.

Machine/Grind Surfaces D.

Machine/Grind Surfaces E.

Machine/Grind Surfaces J.

## Product Repair Bulletin

P/N 3826825

### VGD Vane Assembly

