

## Product Repair Bulletin

P/N 3826282/3826263

### Driven Compressor Diffuser Assembly

Next Higher Assy: GTCP331 Series APU

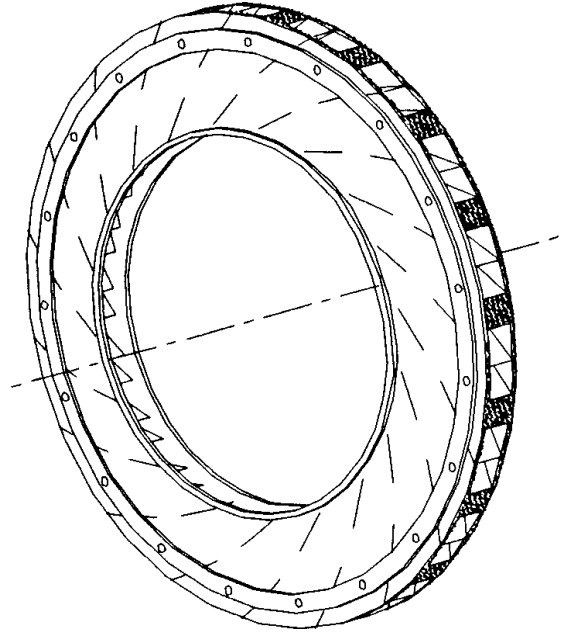

### OEM Manual Repairs

#### Repairs for OEM Manual 49-23-49:

- Dress vanes.
- Braze joint separations as required.
- Procure/Install 3826283-1 Pin (P/N 3826282).

### Additional FAA Approved Repairs

#### Repairs for Major Repairs 9105142/9205041:

- Weld vane tips as required.
- Fabricate/Install -50 Side Plate.
- Fabricate/Install -60 Side Plate.
- Fabricate/Install -10 Vane Insert.
- Fabricate/Install -30 Vane Insert.
- Finish machine diameter B, DX, EX, surface A, FX.
- Drill/line ream holes.

# Product Repair Bulletin

P/N 3826282/3826263

## Driven Compressor Diffuser Assembly

