

## Product Repair Bulletin

P/N 3826262

### Second Stage Diffuser Assembly

NHA: GTCP331 Series APU

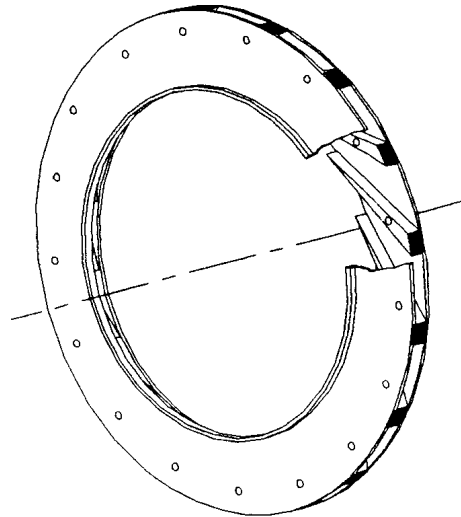

### OEM Manual Repairs

#### Repairs for OEM Manual 49-23-49:

- Dress vanes.
- Metal spray diameter H.
- Machine diameter H.
- Metal spray surface A.
- Metal spray surface C.
- Machine surface C.

### Additional FAA Approved Repairs

#### Repairs for Britt Metal Major Repair 9108063:

- Fabricate/install -110 vane insert.
- Fabricate/Install -50/-70 side plate
- Finish machine.
- Drill/line ream mounting holes.
- Age Diffuser per HT-5089 (-2 configuration only).



# Product Repair Bulletin

P/N 3826262  
Second Stage Diffuser Assembly

