



Product Repair Bulletin

P/N 3826230

First Stage Compressor Diffuser Assembly

NHA: GTCP331 Series APU

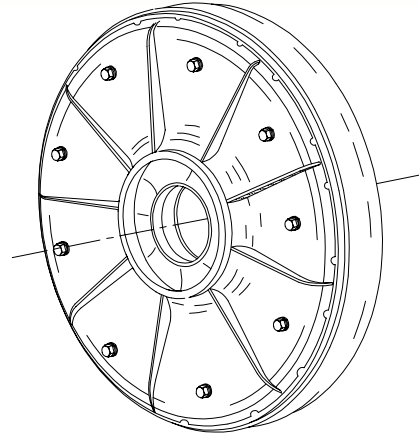

OEM Manual Repairs

Repairs for OEM Manual 49-23-49:

- Disassemble/clean/strip/inspect.
- Metallize diameter D.
- Machine diameter D.
- Apply Sermatel.
- Procure LH9778-3 Nut. (10)
- Procure AN960-10 Washers. (19)
- Procure 7500-10 Packing w/Retainer. (10)
- Procure MS51834C203-20 Stud. (8)
- Procure 3826231-1 Diffuser Vane Assembly.
- Procure S8990-278 Packing.
- Procure NAS1003-15 Bolt. (9)
- Procure 600-6242-10-OS Packing w/Retainer. (9)
- Procure MS51830-201L Insert. (9)

Additional FAA Approved Major Repairs

Repairs for Britt Metal Major Repair 9008231:

- | | |
|--------------------------------|--|
| Weld/dress surface F. | Fabricate/install BMP3826233-10 Deswirl Plug. |
| Weld/dress deswirl vanes. | Fabricate/Install BMP3426320-1 Diff. Cover Assy. |
| Weld/dress diameter D groove. | Fabricate/install BMP3826231-1 Diff. Vane Assy. |
| Clean/iridite. | Fabricate/install BMP3826232-1 Diff. Vane (25). |
| Weld/dress diffuser vanes. | Fabricate/install BMP3826231-10 Diff. Stud (10). |
| Repair cracks in braze joints. | |

Repairs for Britt Metal Major Repair 9303081:

- | | |
|---|--------------------------------|
| Patch/weld diffuser cover bolt hole outer wall. | Metallize air passage contours |
| Apply Electroless Nickel plating. | Machine diameter B. |
| Metallize diameter B. | Machine diameter X |
| Metallize diameter X. | Machine air passage contours. |

**P/N 3826230
Issue 01/01
Section 1**

Product Repair Bulletin

P/N 3826230

First Stage Compressor Diffuser Assembly

