



Product Repair Bulletin

P/N 3826141

Back Shroud Assembly

NHA: GTCP331 Series APU

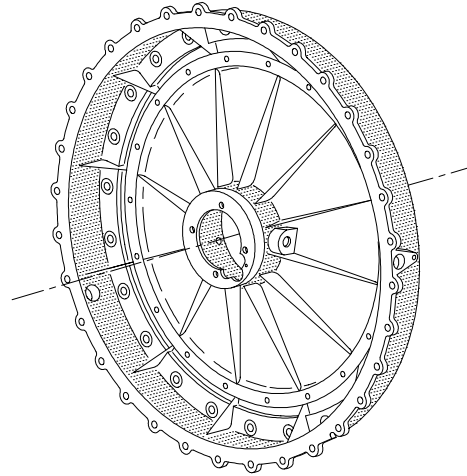

OEM Manual Repairs

Repairs for OEM Manual 49-23-49:

- Procure/install Insert.
- Dress cracks.
- Metallize diameter B.
- Metallize diameter E.
- Metallize diameter K.
- Machine diameter B.
- Machine diameter E.
- Machine diameter K.
- Clean.
- Iridite/paint.

Additional FAA Approved Repairs

Repairs for Britt Metal Major Repair 9109301:

- Weld cracks.
- Metallize surface A.
- Metallize surface S.
- Metallize surface T.
- Machine surface A.
- Machine surface S.
- Machine surface T.
- Line ream mounting holes.
- Set up to restore oil tube bore(s).
- Fabricate/install oil tube sleeve.

Product Repair Bulletin

P/N 3826141

Back Shroud Assembly

