

Product Repair Bulletin

P/N 3826140

Scroll Housing Assembly

NHA: GTCP331 Series APU

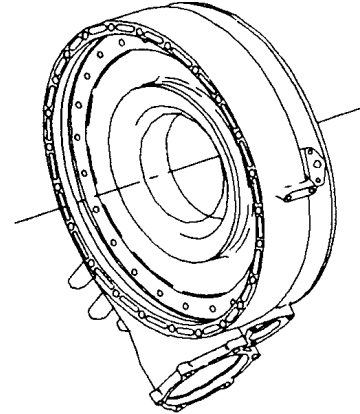

OEM Manual Repairs

Repairs for OEM Manual 49-23-49:

Set-up to install insert(s) as required.
Procure/install surface A insert.
Procure/install surface G insert.
Procure/install surface X insert.
Procure/install IGV 3-hole pad insert.
Procure/install outlet flange insert.
Procure/install mount pad insert.
Metallize diameter AP and O-ring groove.
Metallize contour.

Metallize diameter CA.
Metallize surface of diameter B/DA.
Machine diameter AP & O-ring groove.
Machine contour.
Machine diameter CA.
Machine surface of diameter B/DA.
Clean/iridite.
Apply epoxy paint.

Additional FAA Approved Repairs

Repairs for Britt Metal Major Repair 9010301:

Fabricate/install -100 Plug.

Repairs for Britt Metal Major Repair 9201081:

Metallize surface X.	Machine surface X.
Metallize surface Y.	Machine surface Y.
Metallize surface A.	Machine surface A.

Repairs for Britt Metal Major Repair 9209231:

Weld/dress crack(s) in outlet flange area.	Weld/dress crack(s)/damage on surf. G mount pad.
Metallize diameter AR.	Weld/dress crack(s)/damage on LRU flow sensing module 6-hole mount pad.
Machine diameter AR.	Procure/install surface A oversize insert.
Weld/dress crack(s) in surface A area.	Procure/install surface G oversize insert.
Weld/dress crack(s) in diffuser mount pad area.	Procure/install IGV 3-hole pad oversize insert.
Weld/dress crack(s)/damage 2-hole IGV mount pad.	Procure/install outlet flange oversize insert.
Weld/dress crack(s)/damage CIT sensor mount pad.	Procure/install mount pad oversize insert.
Weld/dress crack(s)/damage 3-hole IGV mount pad.	

Product Repair Bulletin

P/N 3826140

Scroll Housing Assembly

