

Product Repair Bulletin

P/N 3826138

Compressor Housing Assembly

NHA: GTCP331 Series APU

OEM Manual Repairs

Repairs for OEM Manual 49-23-49:

- Metallize diameter B.
- Metallize surface A.
- Metallize diameter P.
- Metallize diameter E.
- Metallize surface D.
- Metallize shroud contour.
- Machine diameter B.
- Machine surface A.
- Machine diameter P.
- Machine diameter E.
- Machine surface D.
- Machine shroud contour.
- Remove/replace pins.
- Clean/iridite.

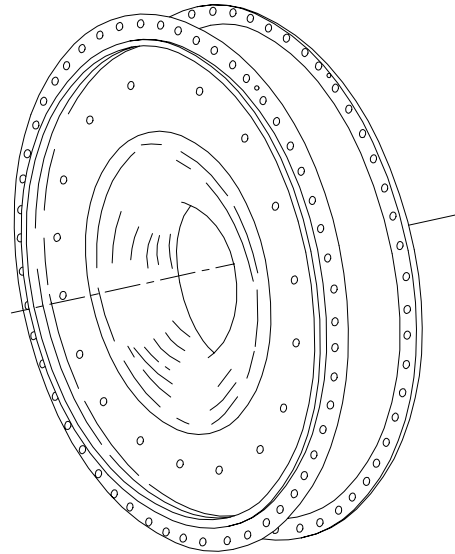

Additional FAA Approved Repairs

Repairs for Britt Metal Major Repair 9106121:

- Metal fuse diameter P.
- Metallize surface X.
- Metal fuse surface X.
- Metallize surface S.
- Metal fuse surface S.
- Machine surface X.
- Machine surface S.
- Fabricate/Install -20 plug.
- Fabricate/Install -13 ring.

Repairs for Britt Metal Major Repair 0105041:

- Fabricate/Install -7 plate.

Product Repair Bulletin

P/N 3826138

Compressor Housing Assembly

