

Product Repair Bulletin

P/N 3826110

Deswirl Assembly

NHA: GTCP331 Series APU

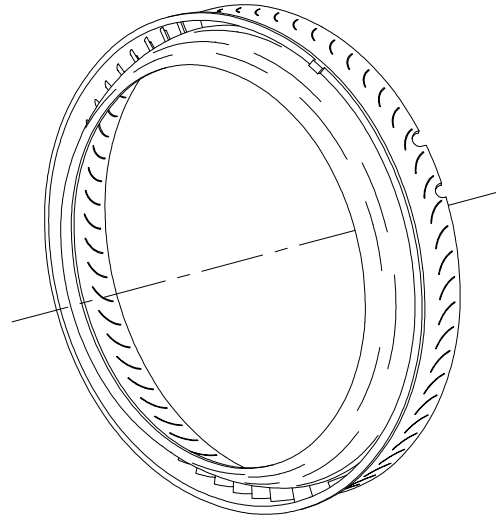

OEM Manual Repairs

Repairs for OEM Manual 49-23-49:

Braze cracks in outer skin.
Metal spray surface C.
Machine surface C.

Additional Air Carrier Approved Repairs

Plasma hardcoat inner flange.

Additional FAA Approved Repairs

Repairs for Britt Metal Major Repair 9101212:

Fabricate/install -903 outer flange.
Fabricate -909 tab.
Install tabs.

Repairs for Britt Metal Major Repair 9104022:

Fabricate/install -901 outer tube.
Fabricate/install -905 inner tube.
Fabricate/Install -907 vanes.
Machine surface A.
Machine diameter B.
Machine tabs.

Repairs for Britt Metal Major Repair 9107311:

Fabricate/install -100 inner flange.

Product Repair Bulletin

P/N 3826110

Deswirl Assembly

