

## Product Repair Bulletin

P/N 3810176

Inlet Housing

NHA: GTCP331 Series APU

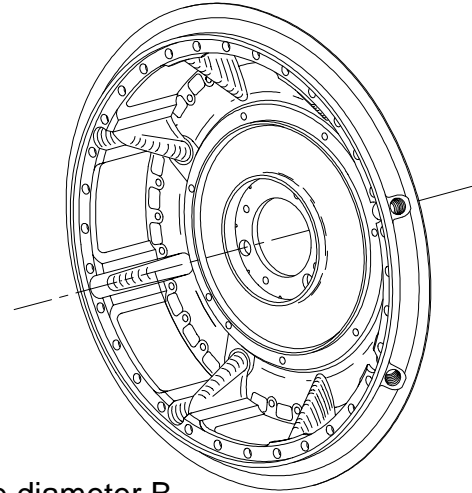

### OEM Manual Repairs

#### Repairs for OEM Manual 49-23-49:

Procure/install S9008G98 pins.  
Procure/install 3611994-1 pin.  
Procure/install MS51830CA201L insert.  
Metallize diameter B.  
Metallize diameter AC.  
Metallize diameter AD.  
Metallize dimension L and M.

Machine diameter B.  
Machine diameter AC.  
Machine diameter AD.  
Machine anti-rotational slot.  
Clean\iridite.  
Apply epoxy paint.  
Machine dimension L and M.

#### Repair for Service Bulletin:

Machine anti-rotational slot and dimension L.  
*Converts -3/-4 to -7/-8 per S/B GTCP331-49-5518*

### Additional FAA Approved Repairs

#### Repairs for Britt Metal Major Repair 9105161:

Weld repair/restore dimension L.  
Weld/dress cracks and/or oil drain holes.  
Weld/machine plenum mounting flange.  
Weld damaged pin holes.  
Set up to install -50/-60 Bushing(s).  
Fabricate/install -50 Bushing.  
Fabricate/install -60 Bushing.  
Metallize diameter AE.  
Metallize surface G.  
Fabricate/Install Bearing Carrier Hub

Metallize surface AB.  
Metallize surface J.  
Metallize surface A.  
Machine diameter AE.  
Machine surface G.  
Machine surface AB.  
Machine surface J.  
Machine surface A.  
Machine welded oil drain holes.

# Product Repair Bulletin

P/N 3810176

Inlet Housing

