

Product Repair Bulletin

P/N 3810138

Compressor Shroud

NHA: GTCP331 Series APU

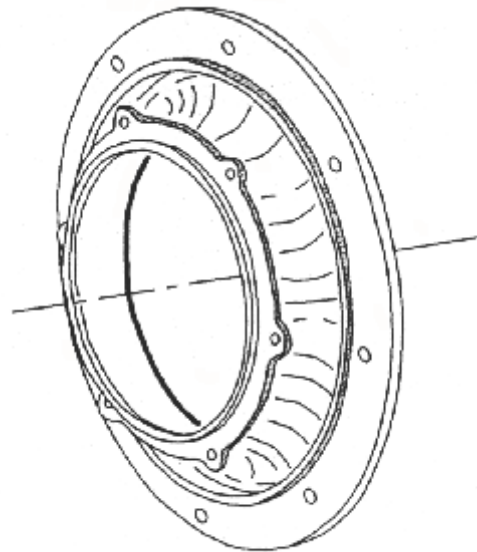

OEM Manual Repairs

Repairs for OEM Manual 49-23-49:

- Metallize/machine surface A.
- Metallize/machine surface N.
- Metallize/machine diameter B.
- Metallize/machine diameter F.
- Metallize/machine diameter G.
- Metallize/machine shroud contour/surface O.
- Weld/dress forward mounting flange.
- Machine forward bolt hole lobes.
- Machine surface M.

Additional FAA Approved Repairs

Repairs for Britt Metal Major Repair 9109181:

- Weld shroud contour.
- Dress shroud contour.

Repairs for Britt Metal Major Repair 9111151:

- Metallize surface M.
- Fabricate/install -50 shroud contour plug.
- Fabricate/install BMP3810176-50 bushing.
- Weld/dress aft mounting flange.

Repairs for Britt Metal Major Repair 0209031:

- Fabricate/install -60 contour ring.

Product Repair Bulletin

P/N 3810138
Compressor Shroud

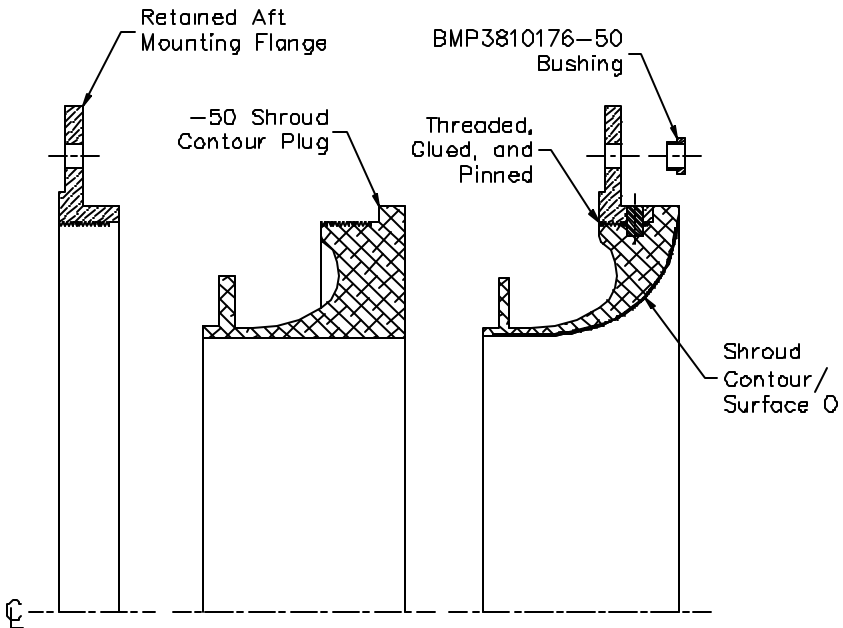
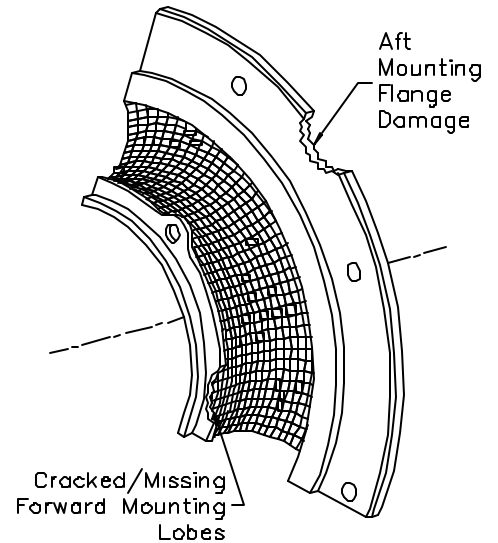

-50 Contour Plug Installation

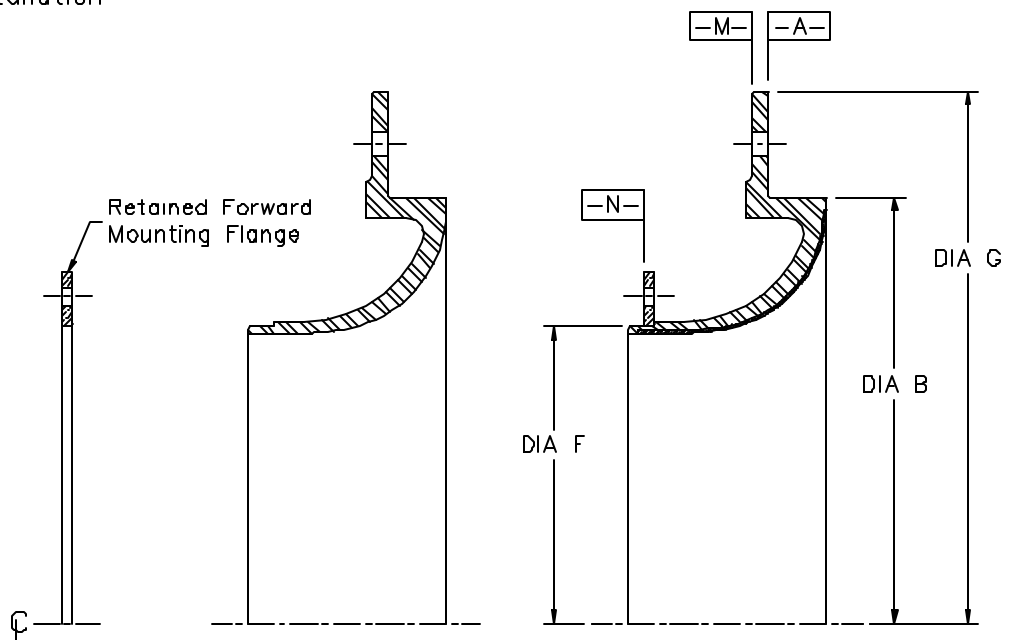

-60 Contour Ring Installation