

Product Repair Bulletin

P/N 379801

Second Stage Diffuser

NHA: GTCP85 Series APU

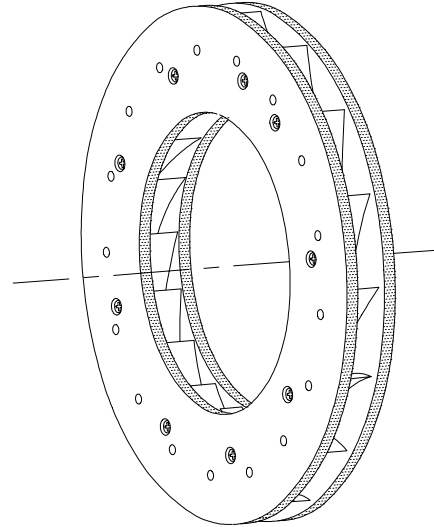

OEM Manual Repairs

Repairs for OEM Manual 49-21-73:

- Metallize surface E.
- Metallize diameter B.
- Machine surface E.
- Machine diameter B.
- Machine diameter C.
- Machine diameter D.
- Machine surface F.
- Dress minor vane damage.
- Weld minor vane damage.
- Line ream mounting holes.
- Clean/iridite.

Additional FAA Approved Repairs:

Repairs for Britt Metal Major Repair 9001091:

Fabricate/Install -23 diffuser plate.
Includes finish machine diameter C, D, surface F and line ream mounting holes

Repairs for Britt Metal Major Repair 9201272:

Fabricate/Install -50 Insert.
Metallize diameter AA.
Machine diameter AA.

Repairs for Britt Metal Major Repair 9206231:

Strip plating.
Apply electroless nickel plating.

Product Repair Bulletin

P/N 379801

Second Stage Diffuser

