



Product Repair Bulletin

P/N 379794/899373/966582

Turbine Torus Assembly

NHA: GTCP85 Series APU

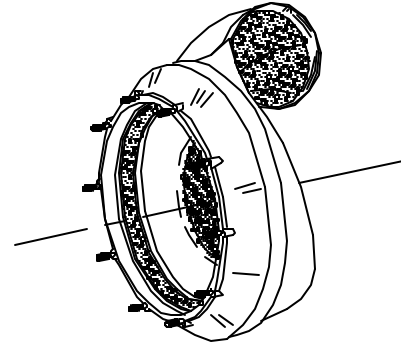

OEM Manual Repairs

Repairs for OEM Manual 49-21-73:

- Weld repair cracks.
- Repair cracked containment ring.
- Fabricate/install patch.
- Metallize inlet ring.
- Install stud(s).

Repair for Service Bulletins:

Machine containment ring for supplemental containment

Converts 379794/899373 to 966582 per S/B 49-3688/5427

Additional FAA Approved Repairs

Repairs for Britt Metal Major Repair 9001151:

- Fabricate/install -61 Cover.
- Fabricate/install -63 Inlet Flange.
- Fabricate/install -55 Torus Ring. (belly band)
- Fabricate/install -45 Ring/Shield Assembly. (heat shield)
- Fabricate/install -59 Ramp.
- Fabricate/install -65/-67 Gusset.
- Fabricate stud.
- Metal fuse diameter B.
- Metallize diameter B.
- Machine diameter B.
- Procure/Install 379794-15 Containment Ring.
- Procure/Install 899373-15 Containment Ring.

Repairs for Britt Metal Major Repair 9004091:

- Fabricate/install -71 Ring. (379794/899373 only)

Repair for Britt Metal Major Repair 9107241:

- Fabricate/install -70 Ring. (966582 only)

Repair for Britt Metal Major Repair 0009071:

- Fabricate/install -15 Containment Ring.

Product Repair Bulletin

P/N 379794/899373/966582

Turbine Torus Assembly

