

Product Repair Bulletin

P/N 379520/698194/3603288

First Stage Diffuser

NHA: GTCP85 Series APU

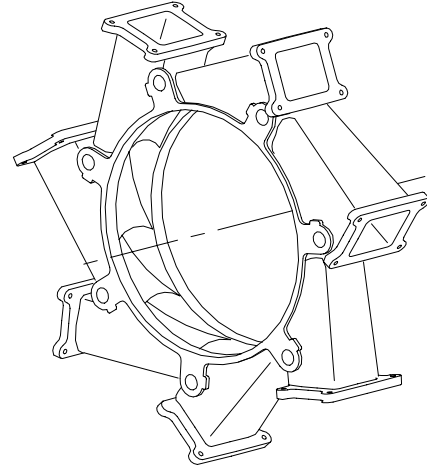

OEM Manual Repairs

Repairs for OEM Manual 49-21-73:

- Procure/install MS1209C1-15 insert.
- Machine diameters AC/AD and surfaces A/C.
- Weld vane tips.
- Dress vanes.
- Repair port flange surfaces.
- Clean/iridite.
- Apply epoxy paint.

Additional FAA Approved Repairs:

Repair for Britt Metal Major Repair 9104111:

- Replace steel vane tip w/ aluminum vane tip.
- Restore mounting holes.
- Weld diameter AC.
- Weld diameter AD.

Repairs for Britt Metal Major Repair 9206231:

- Strip electroless nickel plating.
- Apply electroless nickel plating.

Repairs for Britt Metal Major Repair 9212011:

- Fabricate/install -35 shim.

Repairs for Britt Metal Major Repair 9811161:

- Fabricate/install -19 casting. +

Product Repair Bulletin

P/N 379520/698194/3603288
First Stage Diffuser

