

Product Repair Bulletin

P/N 379515/698195

Second Stage Diffuser Housing Assembly

NHA: GTCP85 Series APU

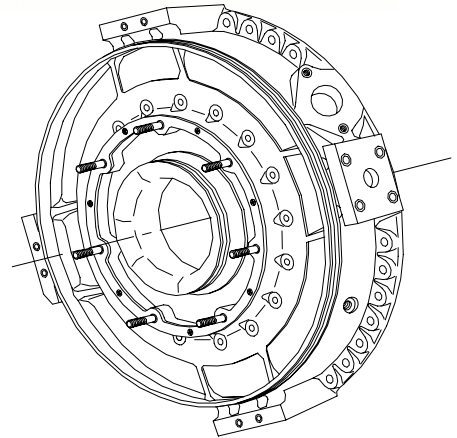

Press for Photo

OEM Manual Repairs

Repairs for OEM Manual 49-21-73:

Procure/install MS51989-105-15 studs(s).
Procure/install RD208SA10L large mount insert.
Procure/install NAS1394-3L small mount insert.
Procure/install RD206SA8L surface AA insert.
Procure/install R1709SB9 air vent insert.
Procure/install RD206SA8L oil tube vent insert.
Fabricate/install sleeve for bolt hole(s). surf AA
Fabricate/install plug(s) for threaded holes(s).
Fabricate/install ring for surface FF.
Repair cracks in mounting pad area.
Plug repair stripped threads in mounting pad.
Weld diameter P.
Metallize diameter P.
Metallize surface UU. (698195 only)
Metallize surface DD. (379515 only)

Metallize diameter A & B.
Metallize surface HH.
Metallize surface AA.
Metallize diameter Q.
Machine diameter P.
Machine surface FF.
Machine surface UU. (698195 only)
Machine surface DD. (379515 only)
Machine diameter A & B.
Machine surface HH.
Machine surface AA.
Machine diameter Q.
Dress/machine air flow contour.
Clean/Anti-corrosion coating
Apply epoxy paint.

Repairs for Service Bulletins:

Weld contour O-ring groove per S/B 49-5631.
Fabricate/install plate surface DD plate per S/B 49-5631.
Features of S/B 49-5199 are accomplished by installing -100/-30-100 Plug.
Features of S/B 49-5631 can be accomplished by installing -100/-30-100 Plug.
Features of S/B 49-7103 are accomplished by metallizing and machining diameter A & B.

Additional FAA Approved Repairs

Repairs for Britt Metal Major Repair 9011261:

Fabricate/install -100 Plug (magnesium).
Fabricate/install -30-100 Plug (aluminum).
Fabricate/install -97 Ring to restore diameter P (magnesium).
Fabricate/install -30-97 Ring to restore diameter P (aluminum).
Fabricate/install -99 Sleeve.
Fabricate/install -101 Shim for Mount Pads
Fabricate/install -102 Shim for surface 'AA'

Repairs for Britt Metal Major Repair 9409121:

Metallize/machine air flow contour.

Repairs for Britt Metal Major Repair 9904071:

Fabricate/Install BMP698195-30 casting for aluminum housings

Repairs for Britt Metal Major Repair 0008111:

Fabricate/Install BMP698195-30 casting for magnesium housings

Product Repair Bulletin

P/N 379515/698195

Second Stage Diffuser Housing Assembly

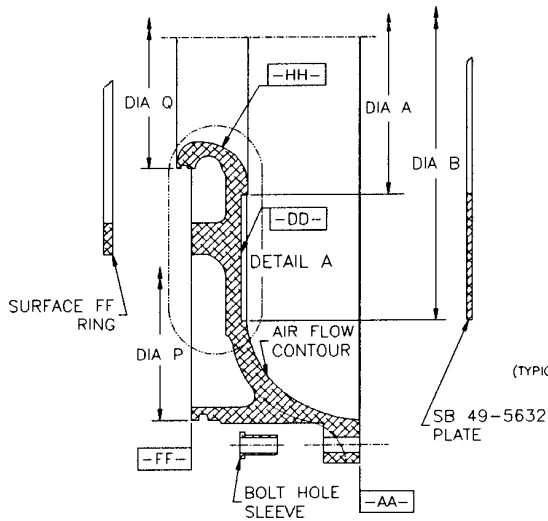
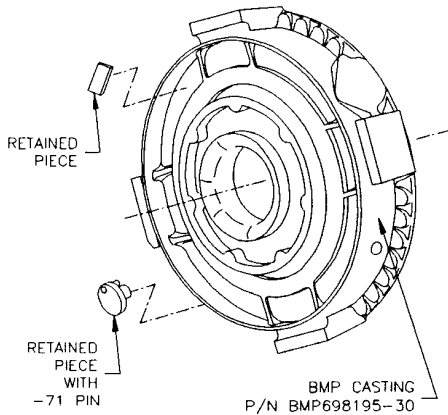
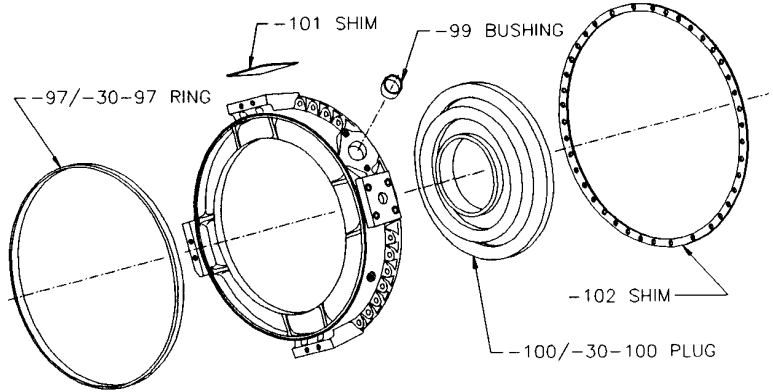
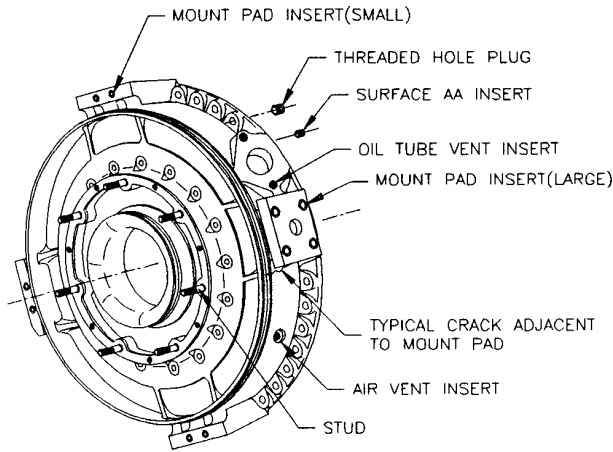

P/N 379515

