



## Product Repair Bulletin

P/N 361771 / 354898 / 359548

### Starter Housing

NHA: ATS100 Series Starters

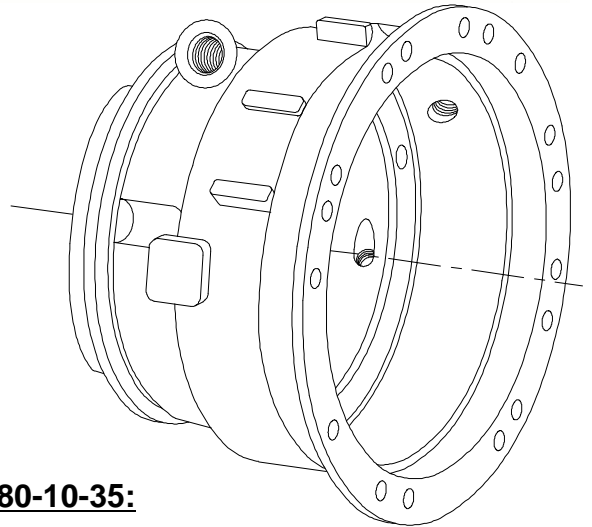

### OEM Manual Repairs

#### Repairs for OEM Manual 80-10-31/ 80-10-33/ 80-10-35:

- Set-up to install inserts as required.
- Procure/install MS124660/MS21208F8-10 insert.
- Procure/install MS24660 insert.
- Procure/install MS124695/MS122120 insert.
- Procure/install 59028-1 insert.
- Fabricate repair bushings(3).
- Install repair bushings (3 total).
- Metallize diameter A.
- Metallize surface H.
- Machine diameter A.
- Machine surface H.
- Weld\dress non-critical areas.
- Clean\chrome pickle\iridite.
- Apply epoxy paint.

### Additional FAA Approved Repairs

#### Repairs for Britt Metal Major Repair 9107251:\*

- |                       |                     |
|-----------------------|---------------------|
| Metallize diameter B. | Machine diameter B. |
| Metallize diameter C. | Machine diameter C. |
| Metallize diameter D. | Machine diameter D. |
| Metallize surface J.  | Machine surface J.  |

#### Repairs for Britt Metal Major Repair 9403151:\*\*

- |                       |                     |
|-----------------------|---------------------|
| Metallize diameter C. | Machine diameter C. |
| Metallize diameter D. | Machine diameter D. |

\* For P/N 361771 only.

\*\* For P/N 359548 only.



# Product Repair

P/N 361771 / 354898 / 359548

Starter Housing

