



## Product Repair Bulletin

P/N 3607748/379529/966580/976987/3850089

### Exhaust Pipe Assembly

NHA: GTCP85 Series APU

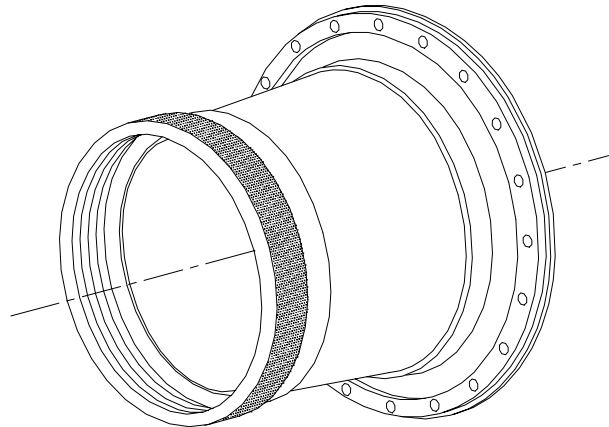

### OEM Manual Repairs

#### Repairs for OEM Manual 49-21-73:

- Weld/dress cracks.
- Set-up to restore threaded bolt holes on aft flange.
- Plug repair threaded bolt holes on aft flange.
- Procure/install aft flange inserts.
- Repair oversize thread in forward flange.

### Additional FAA Approved Repairs:

#### Repair for Britt Metal Major Repair 9004111:

- Fabricate/Install -30 Forward Flange.
- Fabricate/Install -9 Tube.
- Fabricate/Install -7 Aft Flange.
- Fabricate/install -9 Tube and -7 Aft Flange.  
*Converts 379529 & 976987 to 3607748 per S/B 49-A5078*
- Fabricate/Install BMP 3850093-1 Exhaust Hub.
- Fabricate/Install -31 Forward Cone.
- Fabricate/Install -8 Rear Cone.

**Product Repair Bulletin**

**P/N 3607748/379529/966580/976987/3850089**  
**Exhaust Pipe Assembly**

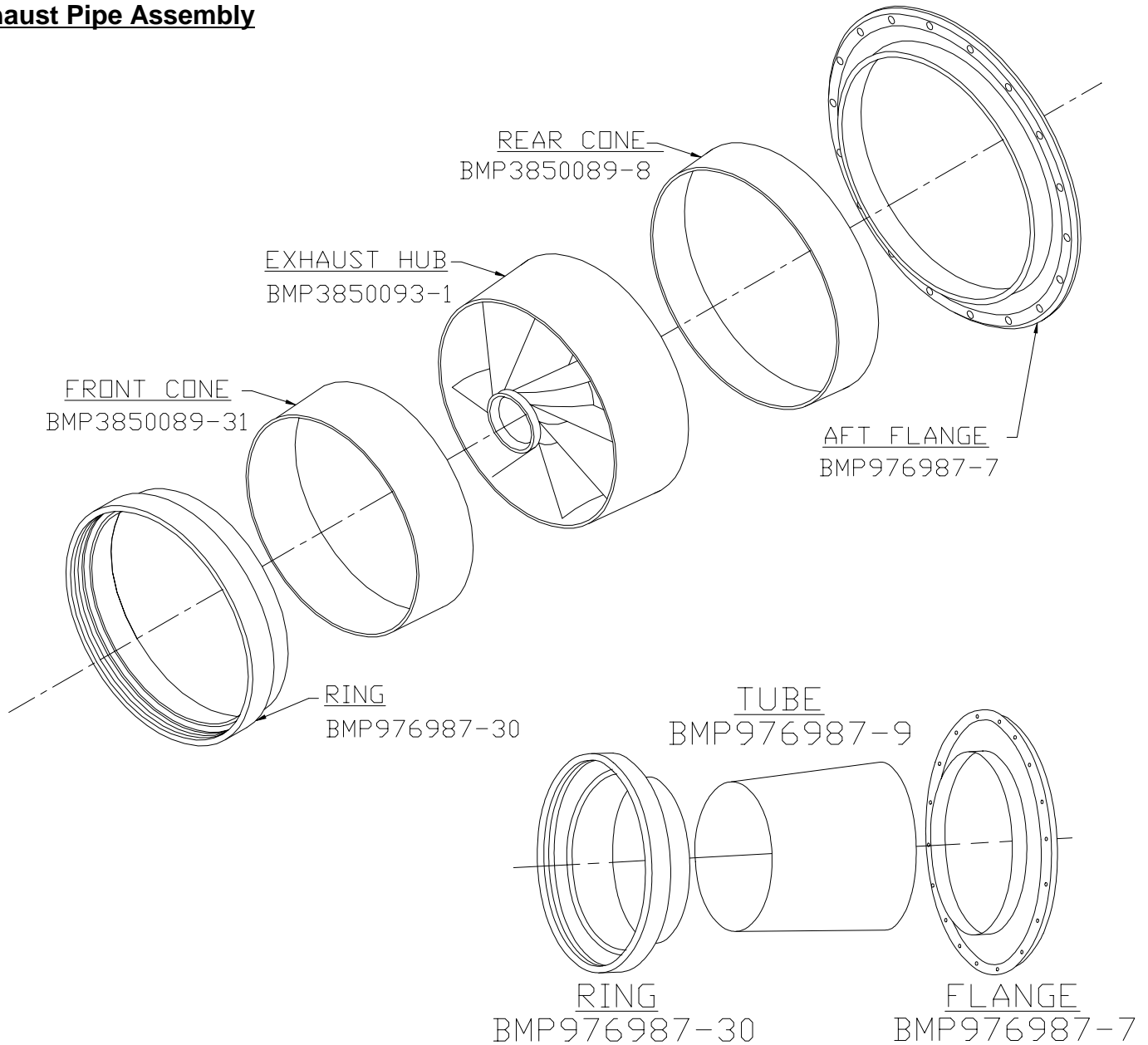

**NOTE: P/N 379529 and P/N 976987-1 are converted to P/N 3607748-1 by incorporating the -9 tube and -7 aft flange per Garrett S/B 49-A5078 and BMP Major Repair 9004111.**

