

## Product Repair Bulletin

P/N 3606988/3600093

### Bearing Carrier Support Assembly

NHA: TSCP700 Series APU

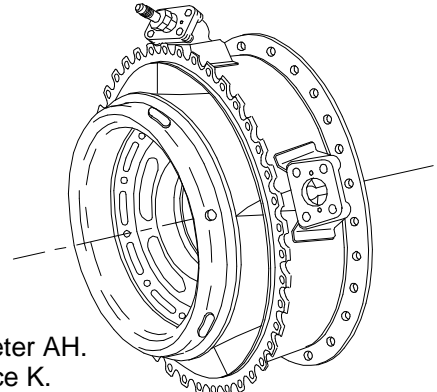

### OEM Manual Repairs

#### Repairs for OEM Manual 49-26-53:

Procure/install MS9389-53 pin.  
Procure/install 357976-3 bushing  
Procure/install MS21209F1-15 insert. (10)  
Fabricate/install -941 Plate. (2)  
Fabricate/install -937 Tab. (2)  
Install S8168-115G200F/equivalent spacer.  
Install 3607797-1/equivalent plates.  
Install 3607796-1/equivalent pins.  
Weld/dress shroud.  
Weld/dress hub.  
Metallize diameter AH.  
Metallize surface AJ.  
Machine surface AJ.

Machine diameter AH.  
Machine surface K.  
Machine diameter M.  
Machine diameter BA.  
Machine diameter AD.  
Machine diameter J.  
Machine surface N.  
Machine diameter L.  
Machine surface BG.  
Machine surface BH.  
Machine diameter AG.  
Machine hub seal grooves.  
Pressure/flow check assembly.

#### Repairs for Service Bulletins:

Rework brazed-in plates to welded-in plates per S/B 49-3479. *Converts 3600093-2 to -3.*  
Rework 1 pin config. to 3 pin config. per S/B 49-3732. *Converts 3600093-2/3/4 to -6/7/5.*  
Rework 3 pin config. to 1 pin config. per S/B 49-3928. *Converts 3606988-1 to -2.*  
Machine oil supply seal groove per S/B 49-5048. *Converts 3600093-2/3/4/5/6/7 to -10/12/14/8/16/18.*

### Additional FAA Approved Repairs

#### Repairs for Britt Metal Major Repair 9105171:

Metal fuse surface AJ.  
Metal fuse diameter AH.  
Metal fuse surface K.  
Metal fuse diameter M.  
Metal fuse diameter BA.  
Metal fuse diameter AD.  
Metal fuse surface BT.  
Metal fuse diameter J.  
Metal fuse hub seal grooves.  
Metal fuse surface N.  
Metal fuse surface X2.  
Metal fuse diameter L.  
Metal fuse surface BG.  
Metal fuse surface BH.  
Metal fuse diameter AG.  
Metal fuse surface X1.  
Machine surface X1.  
Machine surface X2.  
Machine surface BT.  
Fabricate/install -903 hub.  
Fabricate/install -20 Oil Press. Tube Assy.  
Fabricate/install oil scavenge tube assy.  
Install boss support.  
Fabricate install -2 Aft Flange.  
Fabricate/install -1FM Forward Flange.  
Fabricate/install -1IR Inner Ring.  
Fabricate/install -3 Outer Ring.  
Fabricate -200F Spacer.  
Fabricate -797 Plate. (3).  
Fabricate -796 Pin. (3)  
Fabricate -939 boss support.

#### Repairs for Britt Metal Major Repair 0206011:

Fabricate/install -400 Split Bushing.

## Product Repair Bulletin

P/N 3606988/3600093

### Bearing Carrier Support Assembly

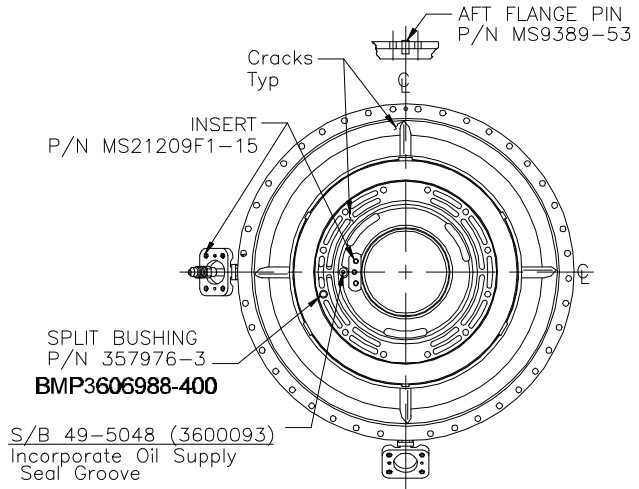
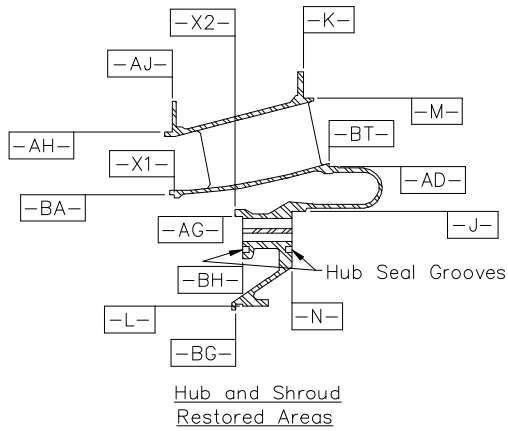

\*\*S/B 49-3479 (3600093)  
Rework brazed-in plates to welded-in plates

\*\*\*S/B 49-3732 (3600093)  
Rework 1-pin config. to 3-pin config.

\*\*\*S/B 49-3928 (3606988)  
Rework 3-pin config. to 1-pin config.

