

Product Repair Bulletin

P/N 3604180/3609474

Fuel Nozzle Swirl

NHA: GTCP85 Combustion
Chamber Liner Assembly

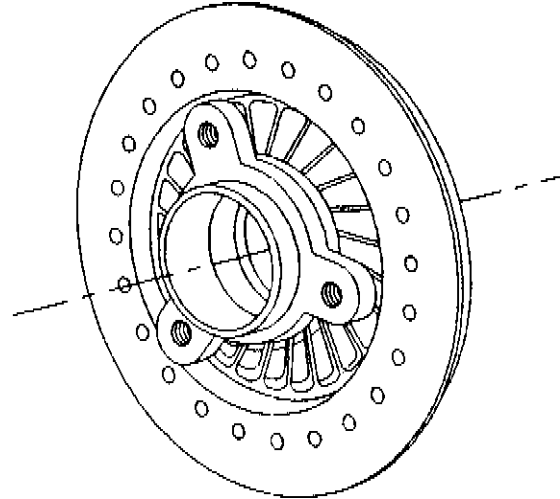

OEM Manual Repairs

Repairs for OEM Manual 49-21-73:

No repairs are currently available.

Additional FAA Approved Repairs

Repairs for Britt Metal Major Repair 9108064:

- Weld build-up flange.
- Fabricate -50/-51 deflector.
- Fabricate -60/-61 flange.
- Fabricate -70/-71 flange.
- Fabricate -80/-81 flange.
- Install deflector.
- Install flange.
- Machine flange.
- Repair cracks in vane gas path area.

Product Repair Bulletin

P/N 3604180/3609474

Fuel Nozzle Swirl

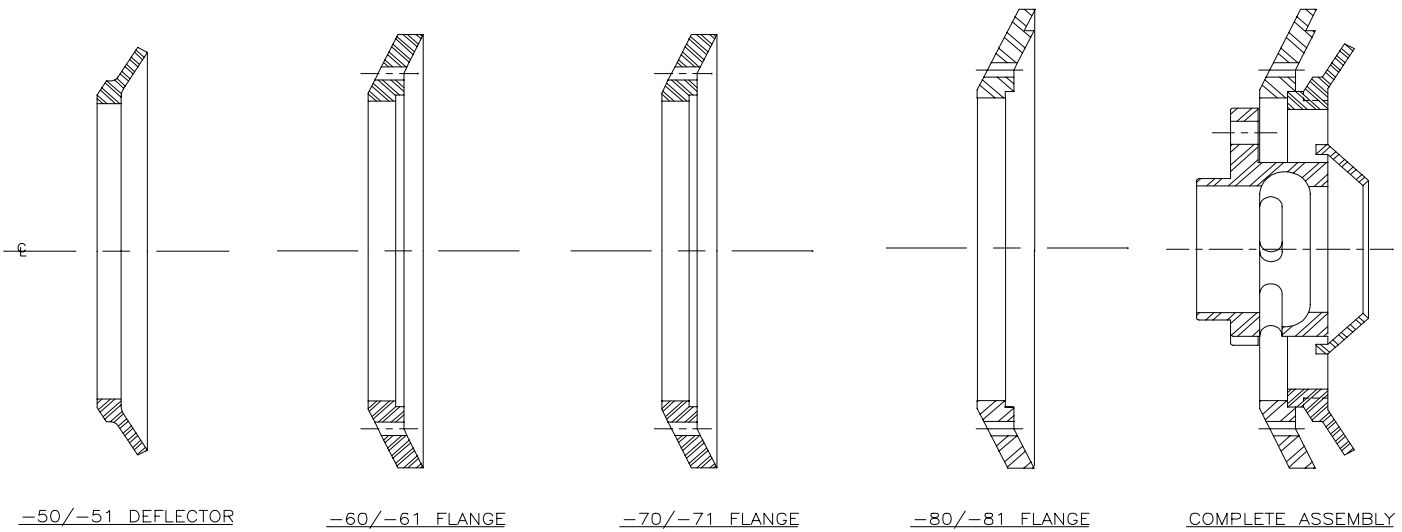
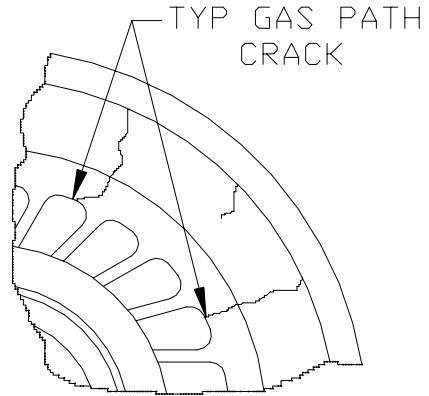

-50 Deflector & -60/-70/-80 Flange used on P/N 3604180
 -51 Deflector & -61/-71/-81 Flange used on P/N 3609474

