



Product Repair Bulletin

P/N 353566/361895

Starter Housing

NHA: ATS100 Series Starter

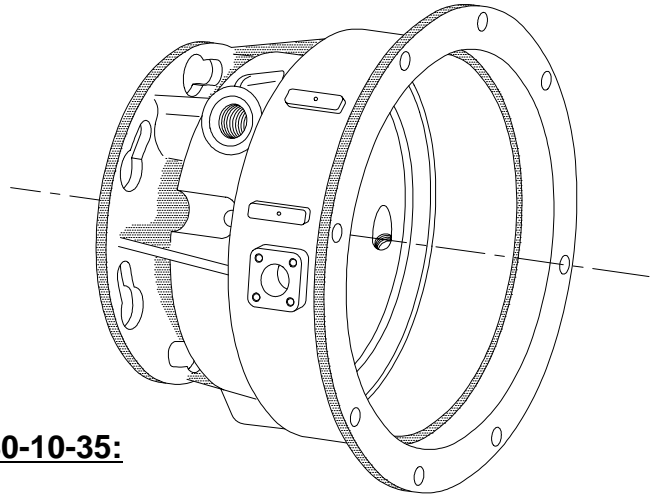

OEM Manual Repairs

Repairs for OEM Manual 80-10-33/80-10-35:

- Procure/install MS124658 insert.
- Procure/install MS124660 insert.
- Procure/install MS122078 insert.
- Procure/install MS122118 insert.
- Procure/install MS122180 insert.
- Fabricate repair bushing. (3)
- Install modified AN960-716 washers.(7)
- Install repair bushing.(3)
- Metallize surface A.
- Metallize diameter B.
- Machine surface A.
- Machine diameter B.
- Machine button holes.
- Chrome pickle/iridite.
- Apply epoxy paint.

Additional FAA Approved Repairs

Repairs for Britt Metal Major Repair 9107252:

- Weld repair button holes. (aluminum housings only)
- Metallize diameter C.
- Metallize diameter E.
- Metallize surface J.
- Metallize surface G.
- Metallize diameter D.
- Machine diameter C.
- Machine diameter E.
- Machine surface J.
- Machine surface G.
- Machine diameter D.
- Machine button holes. (aluminum housings only)

Product Repair Bulletin

P/N 353566/361895
Starter Housing

