



Product Repair Bulletin

P/N 204209

**Turbine Driven Centrifugal
Compressor Nozzle Assembly**

NHA: 204185 Turbine Driven
Centrifugal Compressor

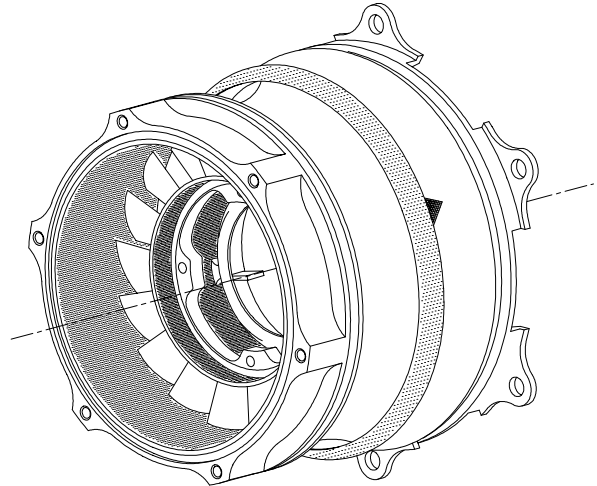

OEM Manual Repairs

Repairs for OEM Manual 21-20-8:
Magnetic particle inspect.

Additional FAA Approved Repairs

Repairs for Britt Metal Major Repair 9107254:

- Cold straighten/repair existing baffle.
- Fabricate/install -9 Baffle.
- Fabricate -50 strut.
- Weld struts.
- Dress vanes.
- Dress stuts.
- Install strut(s).
- Metal fuse vanes.
- Metal fuse tangs.
- Machine tangs.
- Metal fuse diameter A.
- Metal fuse diameter F.
- Metal fuse diameter B.
- Metal fuse surface E.
- Machine diameter A.
- Machine diameter F.
- Machine diameter B.
- Machine surface E.



Product Repair Bulletin

P/N 204209

Turbine Driven Centrifugal
Compressor Nozzle Assembly

