



Product Repair Bulletin

P/N 203727/204182

Compressor Scroll Assembly

NHA: 204050/204950 Turbine Driven Compressor

OEM Manual Repairs

Repairs for OEM Manual 21-50-15/21-50-23:

- Procure/install 1/2-20 UNF-3B insert. (-2 config.)
- Procure 203472-9 lock-wire angle.
- Install/repair lock-wire angle.
- Blend minor surface damage.
- Procure 340-501-9156 outlet flange. (-1 config.)
- Install outlet flange.

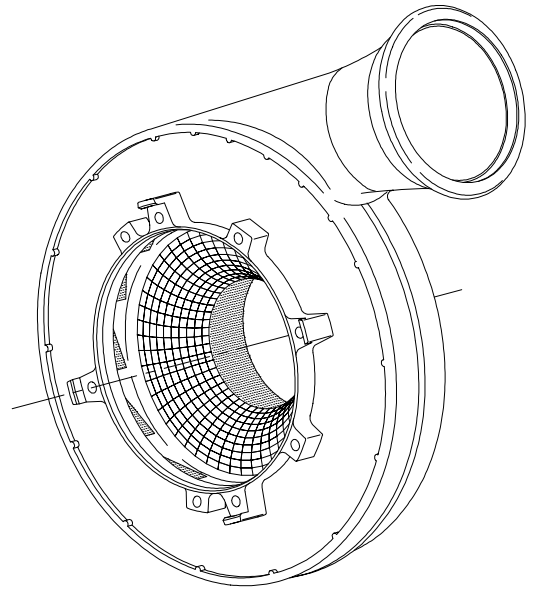

Additional FAA Approved Repairs

Repairs for Britt Metal Major Repair 9107259:

- Weld/dress/straighten inlet/outlet flange(s).
- Patch repair scroll.
- Weld/dress vanes.
- Fabricate/install -9 inlet flange.
- Fabricate/install -15 contour plug.
- Fabricate/install -19 boss. (-2 config.)
- Fabricate/install -20 outlet flange. (-2 config.)
- Pressure test.
- Machine contour.
- Metal fuse surface A.
- Metal fuse diameter E.
- Metal fuse diameter F.
- Machine surface A.
- Machine diameter E.
- Machine diameter F.

P/N 203727
Issue 01/01
Section 2

Product Repair Bulletin

P/N 203727/204182

Compressor Scroll Assembly

